



上海松铭传动机械有限公司
SHANGHAI SONGMING TRANSMISSION MACHINERY CO.,LTD



公司简介 | Company brief introduction

上海松铭传动机械有限公司是一家研究、设计、销售机械传动类产品的公司，供应产品有：WS/WSD/WSS/WSP万向节、SWP/SWC万向联轴器、ML梅花弹性联轴器、XL/XLD星型弹性联轴器、DJM/JMII/SJM/JMIJ/ZJM弹性膜片联轴器、TL弹性柱销套联轴器、HL弹性柱销联轴器、ZL柱销齿式联轴器、制动轮式联轴器、铝合金联轴器、UL/LLA/LLB轮胎联轴器、SL十字滑块联轴器，KC/GL链条联轴器、JS蛇型弹簧联轴器、鼓型齿联轴器、凸缘联轴器、JQ夹壳联轴器、WH/SL滑块联轴器、联轴器配件（弹性体/轮胎体/铝合金外罩壳/联轴器膜片组/联轴器弹簧等）、Z型胀紧联结套及SPA/SPB/SPC/SPZ锥套皮带轮等产品，并承接非标传动零部件的定制加工。

产品咨询订购电话：18621008099

联轴器系列



MXL TYPE (mm) 节距=2.032mm

标示方法:

▼MXL型 同步带轮

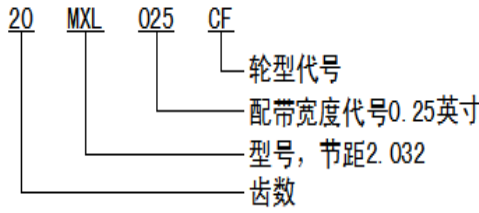
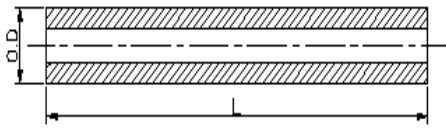

齿数	节径	外径	规格	L	齿数	节径	外径	规格	L
10	6.47	5.96	10MXL100	100	27	17.46	16.96	27MXL100	100
11	7.11	6.61	11MXL100		28	18.11	17.6	28MXL100	
12	7.76	7.25	12MXL100		30	19.4	18.9	30MXL100	
13	8.41	7.9	13MXL100		32	20.7	20.19	32MXL100	
14	9.06	8.55	14MXL100		36	23.29	22.78	36MXL100	
15	9.7	9.19	15MXL100		40	25.87	25.36	40MXL100	
16	10.35	9.84	16MXL100		44	28.46	27.95	44MXL100	
17	11	10.49	17MXL100		48	31.05	30.54	48MXL100	
18	11.64	11.14	18MXL100		50	32.34	31.83	50MXL100	
19	12.29	11.78	19MXL100		60	38.81	38.3	60MXL100	
20	12.94	12.43	20MXL100		70	45.28	44.77	70MXL100	
21	13.58	13.08	21MXL100		72	46.57	46.06	72MXL100	
22	14.23	13.72	22MXL100		80	51.74	51.24	80MXL100	
23	14.88	14.37	23MXL100		84	54.33	53.82	84MXL100	
24	15.52	15.02	24MXL100		96	62.09	61.59	96MXL100	
25	16.17	15.66	25MXL100		100	64.68	64.17	100MXL100	
26	16.82	16.31	26MXL100		120	77.62	77.11	120MXL100	

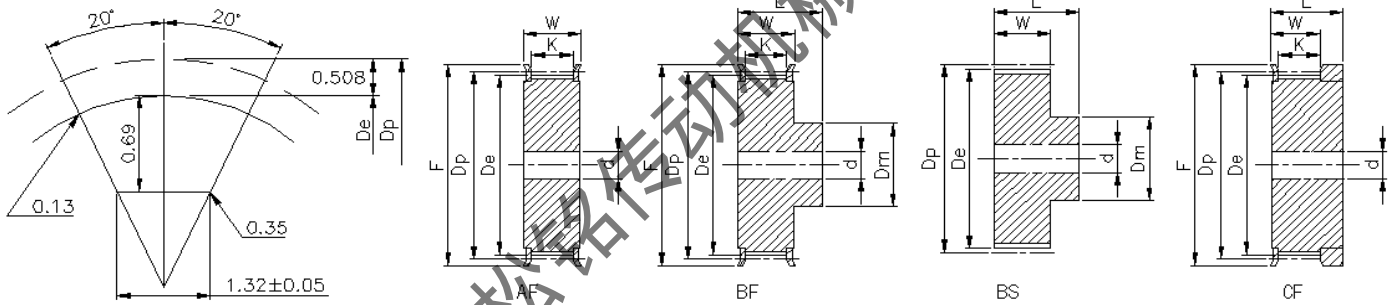

MXL型标准宽度025 (6.4mm)

规格	齿数	形状	节径	外径	W	L	K	X	轮毂直径	内孔	档边外径	档边内径	档边型号
20MXL	20	C/A	12.94	12.43	11	16	7	-	9	6	18	11	F-101811
21MXL	21	C/A	13.58	13.08	11	16	7	-	9	6	18	11	F-101811
22MXL	22	C/A	14.23	13.72	11	16	7	-	9	6	18	11	F-101811
23MXL	23	C/A	14.88	14.37	11	16	7	-	10	6	20	12	F-102012
24MXL	24	C/A	15.52	15.02	11	16	7	-	10	6	20	12	F-102012
25MXL	25	C/A	16.17	15.66	11	16	7	-	10	6	23	12	F-102312
26MXL	26	C/A	16.82	16.31	11	16	7	-	10	6	23	12	F-102312
27MXL	27	C/A	17.46	16.96	11	16	7	-	11	7	23	13	F-102313
28MXL	28	C/A	18.11	17.6	11	16	7	-	11	7	23	13	F-102313
30MXL	30	A/B	19.4	18.9	11	16	7	-	11	7	23	13	F-102313
32MXL	32	A/B	20.7	20.19	11	16	7	-	13	8	26	16	F-102516
36MXL	36	A/B	23.29	22.78	11	16	7	-	15	10	28	18	F-102818
40MXL	40	A/B	25.87	25.36	11	18	7	-	17	10	31	20	F-103120
48MXL	48	A/B	31.05	30.54	11	18	7	-	18	10	35	22	F-103522
60MXL	60	A/B	38.81	38.3	11	18	7	-	28	20	44	32	F-104432
72MXL	72	A/B	46.57	46.06	11	18	7	-	30	20	51	36	F-105136
84MXL	84	A/B	54.33	53.82	11	18	7	-	35	23	61	41	F-106141
96MXL	96	A/B	62.09	61.59	11	18	7	-	42	28	69	50	F-106950
120MXL	120	A/B	77.62	77.11	11	18	7	-	56	37	86	66	F-108666

▼ XL型 同步带轮

XL型齿形图:

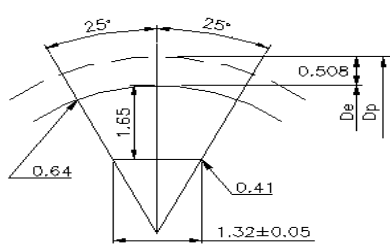

表示方法:

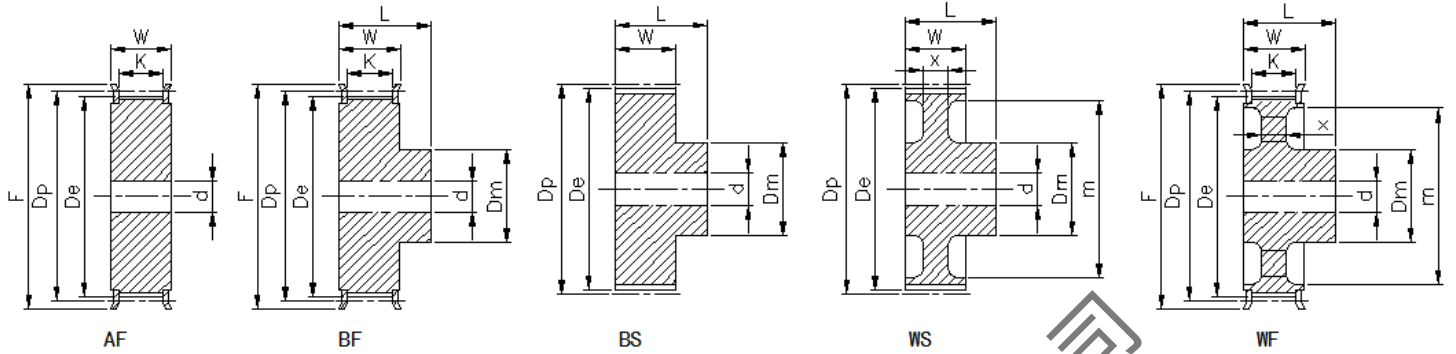
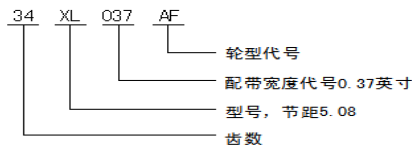

XL型标准皮带宽037 (9.5mm)

规格	齿数	形状	节径	外径	W	L	K	X	轮毂直径	内孔	透孔外径	档边外径	档边内径	档边型号
10XL	10	A\B	16.17	15.66	15	23	11	-	9.5	6	-	23	12	F-102312
11XL	11	A\B	17.79	17.28	15	23	11	-	9.5	6	-	23	13	F-102313
12XL	12	A\B	19.4	18.9	15	23	11	-	10	6	-	25	14	F-102514
14XL	14	A\B	22.64	22.13	15	23	11	-	15	6	-	28	18	F-102818
15XL	15	A\B	24.26	23.75	15	23	11	-	15	6	-	28	18	F-102818
16XL	16	A\B	25.87	25.36	15	23	11	-	16	6	-	31	20	F-103120
18XL	18	A\B	29.11	28.6	15	23	11	-	22	6	-	33	22	F-103322
19XL	19	A\B	30.72	30.22	15	23	11	-	24	6	-	35	22	F-103522
20XL	20	A\B	32.34	31.83	15	23	11	-	27	6	-	38	26	F-103826
21XL	21	A\B	33.96	33.45	15	23	11	-	28	6	-	38	26	F-103826
22XL	22	A\B	35.57	35.07	15	23	11	-	29	6	-	43	28	F-104328
24XL	24	A\B	38.81	38.3	15	23	11	-	33	8	-	44	32	F-104432
25XL	25	A\B	40.43	39.92	15	23	11	-	38	8	-	44	32	F-104432
26XL	26	A\B	42.04	41.53	15	23	11	-	38	8	-	47	34	F-104734
28XL	28	A\B	45.28	44.77	15	23	11	-	38	8	-	48	36	F-104836
30XL	30	A\B	48.51	48	15	23	11	-	38	8	-	55	39	F-105539
32XL	32	A\B	51.74	51.24	16	23	11	-	38	8	-	57	41	F-155741
34XL	34	A\B	54.98	54.47	16	23	11	-	38	8	-	61	41	F-156141
36XL	36	A\B	58.21	57.7	16	25	11	-	38	8	-	61	41	F-156141
38XL	38	A\B	61.45	60.94	16	25	11	-	38	8	-	65	50	F-156550
40XL	40	A\B	64.68	64.17	16	25	11	-	38	8	-	69	50	F-156950
42XL	42	A\B	67.91	67.41	16	25	11	-	38	8	-	74	53	F-157453
44XL	44	A\B	71.15	70.64	16	25	11	5	38	8	-	78	58	F-157858
45XL	45	W	72.77	72.26	16	25	11	5	38	10	60	-	-	-
48XL	48	W	77.62	77.11	16	25	11	5	38	10	64	-	-	-
50XL	50	W	80.85	83.58	16	25	11	5	38	10	67	-	-	-
57XL	57	W	90.55	91.66	16	25	11	5	38	10	74	-	-	-
60XL	60	W	97.02	96.51	16	25	11	5	38	10	83	-	-	-
70XL	70	W	113.19	112.68	16	25	11	5	38	10	100	-	-	-
72XL	72	W	116.43	115.92	16	25	11	5	38	10	102	-	-	-

XL型齿形图:

表示方法:

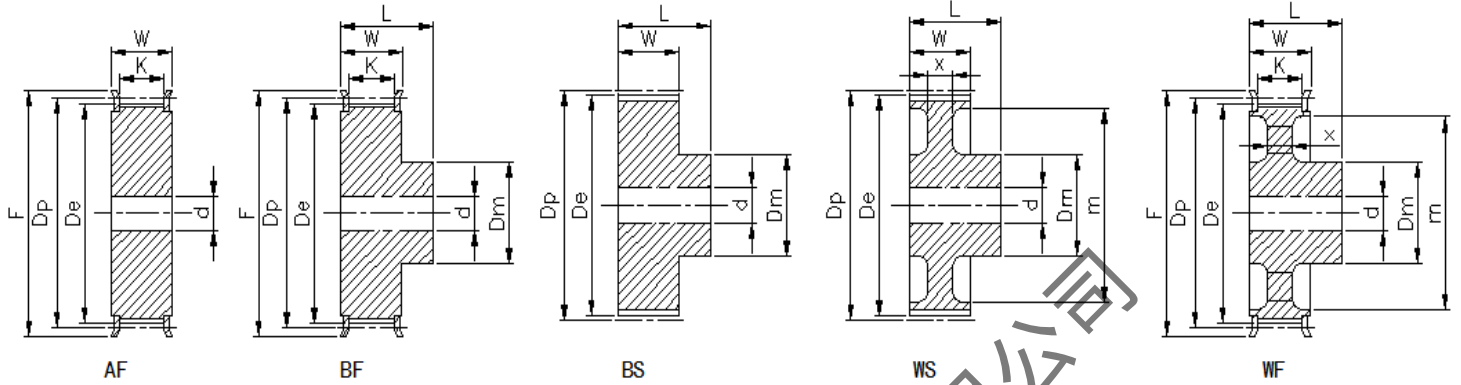
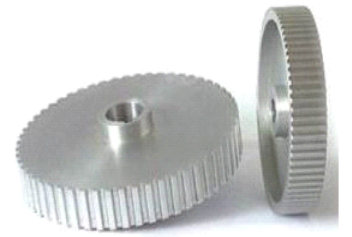
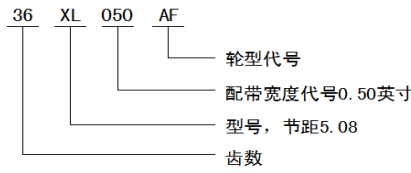
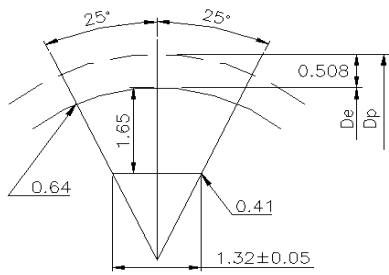

XL型标准皮带宽050 (12.7mm)

规格	齿数	形状	节径	外径	W	L	K	X	轮毂直径	内孔	透孔外径	档边外径	档边内径	档边型号
10XL	10	A\B	16.17	15.66	18	30	14	-	9.5	6	-	23	12	F-102312
11XL	11	A\B	17.79	17.28	18	30	14	-	9.5	6	-	23	13	F-102313
12XL	12	A\B	19.4	18.9	18	30	14	-	10	6	-	25	14	F-102514
14XL	14	A\B	22.64	22.13	18	30	14	-	15	6	-	28	18	F-102818
15XL	15	A\B	24.26	23.75	18	30	14	-	15	6	-	28	18	F-102818
16XL	16	A\B	25.87	25.36	18	30	14	-	16	6	-	31	20	F-103120
18XL	18	A\B	29.11	28.6	18	30	14	-	22	6	-	33	22	F-103322
19XL	19	A\B	30.72	30.22	18	30	14	-	24	6	-	35	22	F-103522
20XL	20	A\B	32.34	31.83	18	30	14	-	27	6	-	38	26	F-103826
21XL	21	A\B	33.96	33.45	18	30	14	-	28	6	-	38	26	F-103826
22XL	22	A\B	35.57	35.07	18	30	14	-	29	6	-	43	28	F-104328
24XL	24	A\B	38.81	38.3	18	30	14	-	33	8	-	44	32	F-104432
25XL	25	A\B	40.43	39.92	18	30	14	-	38	8	-	44	32	F-104432
26XL	26	A\B	42.04	41.53	18	30	14	-	38	8	-	47	34	F-104734
28XL	28	A\B	45.28	44.77	18	30	14	-	38	8	-	48	36	F-104836
30XL	30	A\B	48.51	48	18	30	14	-	38	8	-	55	39	F-105539
32XL	32	A\B	51.74	51.24	19	32	14	-	38	8	-	57	41	F-155741
34XL	34	A\B	54.98	54.47	19	32	14	-	38	8	-	61	41	F-156141
36XL	36	A\B	58.21	57.7	19	32	14	-	38	8	-	61	41	F-156141
38XL	38	A\B	61.45	60.94	19	32	14	-	38	8	-	65	50	F-156550
40XL	40	A\B	64.68	64.17	19	32	14	-	38	8	-	69	50	F-156950
42XL	42	A\B	67.91	67.41	19	32	14	-	38	8	-	74	53	F-157453
44XL	44	A\B	71.15	70.64	19	32	14	6	38	8	-	78	58	F-157858
45XL	45	W	72.77	72.26	19	32	14	6	38	10	60	-	-	-
48XL	48	W	77.62	77.11	19	32	14	6	38	10	64	-	-	-
50XL	50	W	80.85	83.58	19	32	14	6	38	10	67	-	-	-
57XL	57	W	90.55	91.66	19	32	14	6	38	10	74	-	-	-
60XL	60	W	97.02	96.51	19	32	14	6	38	10	83	-	-	-
70XL	70	W	113.19	112.68	19	32	14	6	38	10	100	-	-	-
72XL	72	W	116.43	115.92	19	32	14	6	38	10	102	-	-	-

▼ L型 同步带轮

L型齿形图:

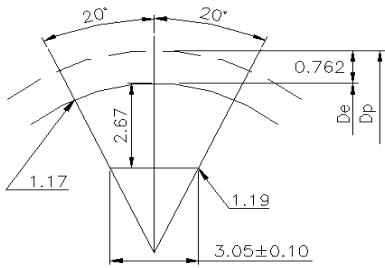

表示方法:

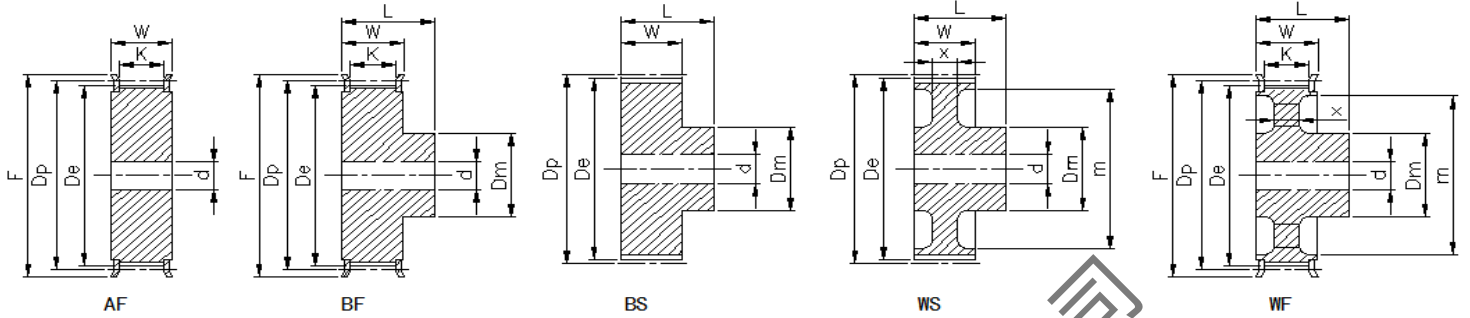
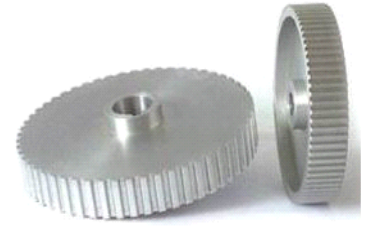
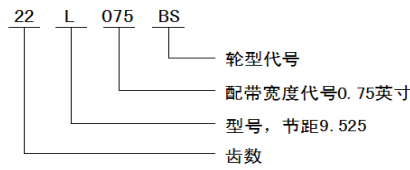

L型标准皮带宽075 (19.1mm)

规格	齿数	形状	节径	外径	W	L	K	X	轮毂直径	内孔	透孔外径	档边外径	档边内	档边型号
10L	10	A\B	30.32	29.56	26	38	21	-	20	8	-	35	22	F-153522
12L	12	A\B	36.38	35.62	26	38	21	-	25	8	-	43	28	F-154328
14L	14	A\B	42.45	41.68	26	38	21	-	30	10	-	47	34	F-154734
15L	15	A\B	45.48	44.72	26	38	21	-	32	10	-	51	36	F-155136
16L	16	A\B	48.51	47.75	26	38	21	-	34	12	-	55	39	F-155539
17L	17	A\B	51.54	50.78	26	38	21	-	35	12	-	57	41	F-155741
18L	18	A\B	54.57	53.81	26	38	21	-	36	12	-	61	41	F-156141
19L	19	A\B	57.61	56.84	26	38	21	-	38	12	-	65	50	F-156550
20L	20	A\B	60.64	59.88	26	38	21	-	40	12	-	65	50	F-156550
21L	21	A\B	63.67	62.91	26	38	21	-	42	12	-	69	50	F-156950
22L	22	A\B	66.7	65.94	26	38	21	-	44	12	-	74	53	F-157453
24L	24	A\B	72.77	72	26	38	21	-	44	12	-	78	58	F-157858
25L	25	A\B	75.8	75.04	26	38	21	-	44	12	-	83	63	F-158363
26L	26	A\B	78.83	78.07	26	38	21	-	44	12	-	86	66	F-158666
28L	28	A\B	84.89	84.13	26	38	21	-	50	12	-	93	75	F-157375
30L	30	A\B	90.96	90.2	26	38	21	-	50	14	-	99	78	F-159978
32L	32	A\B	97.02	96.26	26	38	21	-	50	14	-	105	84	F-1510584
34L	34	A\B	103.08	102.32	26	41	21	-	56	14	-	112	90	F-1511290
36L	36	A\B	109.15	108.39	26	41	21	-	56	14	-	115	90	F-1511590
38L	38	A\B	115.22	114.45	26	41	21	-	60	14	-	126	100	F-15126100
40L	40	A\B	121.28	120.51	26	41	21	-	60	14	-	126	100	F-15126100
42L	42	A\B	127.34	126.58	26	41	21	-	60	14	-	131	111	F-15131111
44L	44	A\B	133.4	132.64	26	46	21	-	65	14	-	138	125	F-15138125
45L	45	W	136.44	135.67	26	46	21	9	65	14	116	-	-	-
48L	48	W	145.53	144.77	26	46	21	9	65	14	124	-	-	-
50L	50	W	151.6	150.83	26	46	21	9	65	14	130	-	-	-
56L	56	W	169.79	169.02	26	46	21	9	65	14	148	-	-	-
60L	60	W	181.91	181.15	26	46	21	9	65	14	160	-	-	-
72L	72	W	218.3	217.53	26	46	21	9	65	14	197	-	-	-
84L	84	W	254.68	253.92	26	46	21	9	65	14	233	-	-	-

▼ L型 同步带轮

L型齿形图:

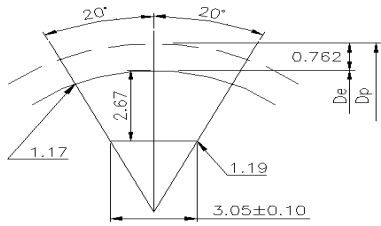

表示方法:

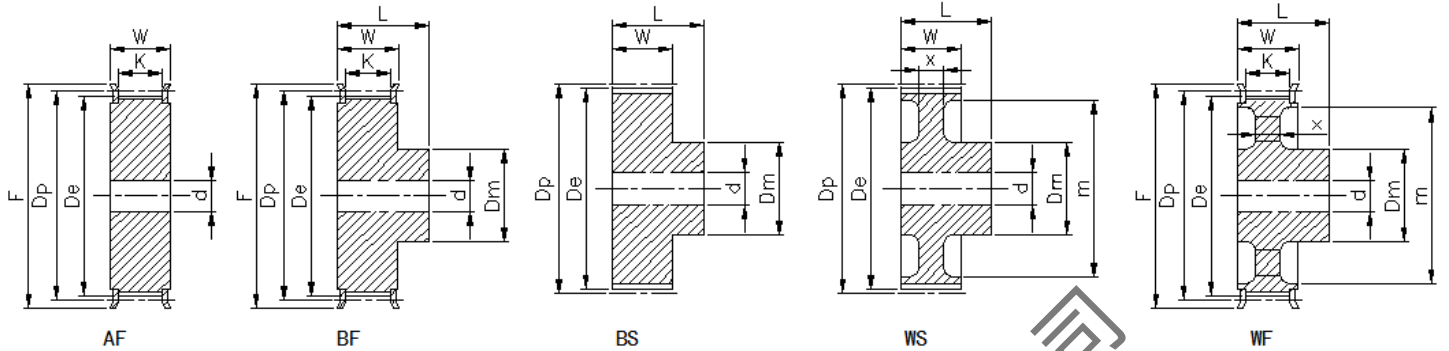
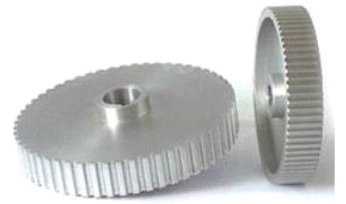
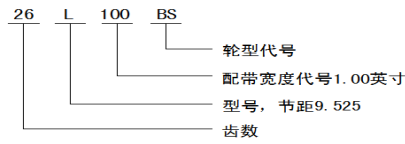

L型标准皮带宽100 (25.4mm)

规格	齿数	形状	节径	外径	W	L	K	X	轮毂直径	内孔	透孔外径	档边外	档边内径	档边型号
10L	10	A\B	30.32	29.56	33	45	28	-	20	8	-	35	22	F-153522
12L	12	A\B	36.38	35.62	33	45	28	-	25	8	-	43	28	F-154328
14L	14	A\B	42.45	41.68	33	45	28	-	30	10	-	47	34	F-154734
15L	15	A\B	45.48	44.72	33	45	28	-	32	10	-	51	36	F-155136
16L	16	A\B	48.51	47.75	33	45	28	-	34	12	-	55	39	F-155539
17L	17	A\B	51.54	50.78	33	45	28	-	35	12	-	57	41	F-155741
18L	18	A\B	54.57	53.81	33	45	28	-	36	12	-	61	41	F-156141
19L	19	A\B	57.61	56.84	33	45	28	-	38	12	-	65	50	F-156550
20L	20	A\B	60.64	59.88	33	45	28	-	40	12	-	65	50	F-156550
21L	21	A\B	63.67	62.91	33	45	28	-	42	12	-	69	50	F-156950
22L	22	A\B	66.7	65.94	33	45	28	-	44	12	-	74	53	F-157453
24L	24	A\B	72.77	72	33	45	28	-	44	12	-	78	58	F-157858
25L	25	A\B	75.8	75.04	33	45	28	-	44	12	-	83	63	F-158363
26L	26	A\B	78.83	78.07	33	45	28	-	44	12	-	86	66	F-158666
28L	28	A\B	84.89	84.13	33	45	28	-	50	12	-	93	75	F-157375
30L	30	A\B	90.96	90.2	33	45	28	-	50	14	-	99	78	F-159978
32L	32	A\B	97.02	96.26	33	45	28	-	50	14	-	105	84	F-1510584
34L	34	A\B	103.08	102.32	33	48	28	-	56	14	-	112	90	F-1511290
36L	36	A\B	109.15	108.39	33	48	28	-	56	14	-	115	90	F-1511590
38L	38	A\B	115.22	114.45	33	48	28	-	60	14	-	126	100	F-15126100
40L	40	A\B	121.28	120.51	33	48	28	-	60	14	-	126	100	F-15126100
42L	42	A\B	127.34	126.58	33	48	28	-	60	14	-	131	111	F-15131111
44L	44	A\B	133.4	132.64	33	53	28	-	65	14	-	138	125	F-15138125
45L	45	W	136.44	135.67	33	53	28	11	65	14	116	-	-	-
48L	48	W	145.53	144.77	33	53	28	11	65	14	124	-	-	-
50L	50	W	151.6	150.83	33	53	28	11	65	14	130	-	-	-
56L	56	W	169.79	169.02	33	53	28	11	65	14	148	-	-	-
60L	60	W	181.91	181.15	33	53	28	11	65	14	160	-	-	-
72L	72	W	218.3	217.53	33	53	28	11	65	14	197	-	-	-
84L	84	W	254.68	253.92	33	53	28	11	65	14	233	-	-	-

L型齿形图:

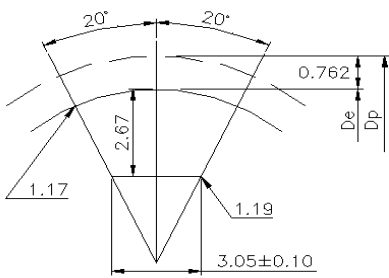

表示方法:

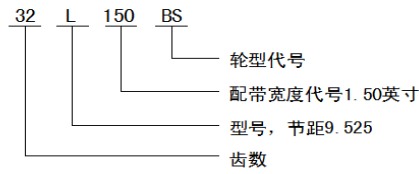

▼ L型 同步带轮

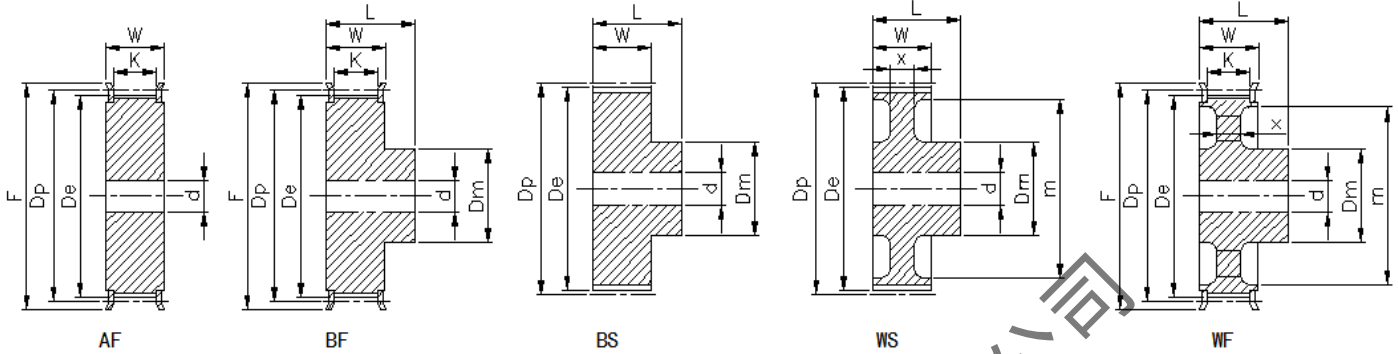
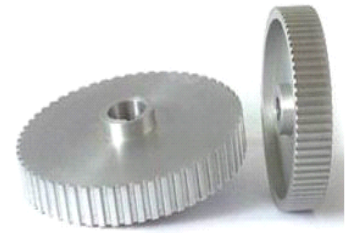

L型标准皮带宽150 (38.1mm)

规格	齿数	形状	节径	外径	W	L	K	X	轮毂直径	内孔	透孔外	档边外径	档边内	档边型号
10L	10	A\B	30.32	29.56	45	57	40	-	20	8	-	35	22	F-153522
12L	12	A\B	36.38	35.62	45	57	40	-	25	8	-	43	28	F-154328
14L	14	A\B	42.45	41.68	45	57	40	-	30	10	-	47	34	F-154734
15L	15	A\B	45.48	44.72	45	57	40	-	32	10	-	51	36	F-155136
16L	16	A\B	48.51	47.75	45	57	40	-	34	12	-	55	39	F-155539
17L	17	A\B	51.54	50.78	45	57	40	-	35	12	-	57	41	F-155741
18L	18	A\B	54.57	53.81	45	57	40	-	36	12	-	61	41	F-156141
19L	19	A\B	57.61	56.84	45	57	40	-	38	12	-	65	50	F-156550
20L	20	A\B	60.64	59.88	45	57	40	-	40	12	-	65	50	F-156550
21L	21	A\B	63.67	62.91	45	57	40	-	42	12	-	69	50	F-156950
22L	22	A\B	66.7	65.94	45	57	40	-	44	12	-	74	53	F-157453
24L	24	A\B	72.77	72	45	57	40	-	44	12	-	78	58	F-157858
25L	25	A\B	75.8	75.04	45	57	40	-	44	12	-	83	63	F-158363
26L	26	A\B	78.83	78.07	45	57	40	-	44	12	-	86	66	F-158666
28L	28	A\B	84.89	84.13	45	57	40	-	50	12	-	93	75	F-157375
30L	30	A\B	90.96	90.2	45	57	40	-	50	14	-	99	78	F-159978
32L	32	A\B	97.02	96.26	45	57	40	-	50	14	-	105	84	F-1510584
34L	34	A\B	103.08	102.32	45	59	40	-	56	14	-	112	90	F-1511290
36L	36	A\B	109.15	108.39	45	59	40	-	56	14	-	115	90	F-1511590
38L	38	A\B	115.22	114.45	45	59	40	-	60	14	-	126	100	F-15126100
40L	40	A\B	121.28	120.51	45	59	40	-	60	14	-	126	100	F-15126100
42L	42	A\B	127.34	126.58	45	59	40	-	60	14	-	131	111	F-15131111
44L	44	A\B	133.4	132.64	45	59	40	-	65	14	-	138	125	F-15138125
45L	45	W	136.44	135.67	45	59	40	15	65	14	116	-	-	-
48L	48	W	145.53	144.77	45	59	40	15	65	14	124	-	-	-
50L	50	W	151.6	150.83	45	59	40	15	65	14	130	-	-	-
56L	56	W	169.79	169.02	45	59	40	15	65	14	148	-	-	-
60L	60	W	181.91	181.15	45	59	40	15	65	14	160	-	-	-
72L	72	W	218.3	217.53	45	59	40	15	65	14	197	-	-	-
84L	84	W	254.68	253.92	45	59	40	15	65	14	233	-	-	-

▼ H型 同步带轮

H型齿形图:

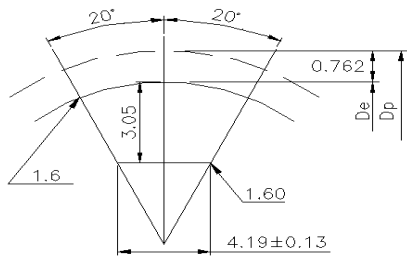

表示方法:

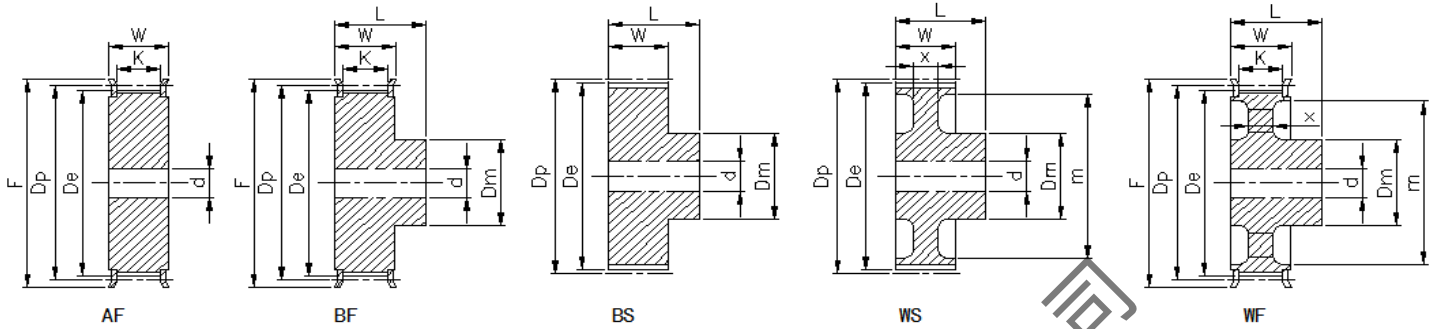
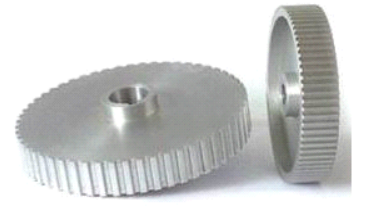
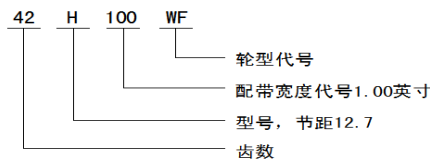

H型标准皮带宽100 (25.4mm)

规格	齿数	形状	节径	外径	W	L	K	X	轮毂直径	内孔	透孔外径	档边外径	档边内径	档边型号
14H	14	A\B	56.6	55.22	33	48	28	-	38	20	-	61	41	F-156141
15H	15	A\B	60.64	59.27	33	48	28	-	46	20	-	65	50	F-156550
16H	16	A\B	64.68	63.31	33	48	28	-	46	20	-	69	50	F-156950
18H	18	A\B	72.77	71.39	33	48	28	-	55	20	-	78	58	F-157858
19H	19	A\B	76.81	75.44	33	48	28	-	56	20	-	83	63	F-158363
20H	20	A\B	80.85	79.48	33	48	28	-	58	20	-	86	66	F-158666
21H	21	A\B	84.89	83.52	33	48	28	-	58	20	-	90	69	F-159069
22H	22	A\B	88.94	87.56	33	48	28	-	62	20	-	93	75	F-159375
24H	24	A\B	97.02	96.65	33	48	28	-	66	20	-	105	84	F-1510584
25H	25	A\B	101.06	99.69	33	48	28	-	70	20	-	108	84	F-1510884
26H	26	A\B	105.11	103.73	33	48	28	-	74	20	-	112	90	F-1511290
28H	28	A\B	113.19	111.82	33	48	28	-	74	20	-	118	90	F-1511890
30H	30	A\B	121.28	119.9	33	48	28	-	78	20	-	126	100	F-15126100
32H	32	A\B	129.3	127.99	33	53	28	-	82	20	-	136	118	F-15136118
34H	34	A\B	137.45	136.07	33	53	28	-	82	20	-	146	128	F-15146128
36H	36	A\B	145.53	144.16	33	53	28	-	82	20	-	152	134	F-15152134
38H	38	A\B	153.62	152.24	33	53	28	-	88	20	-	160	140	F-15160140
40H	40	A\B	161.7	160.33	33	53	28	-	88	20	-	170	150	F-15170150
42H	42	B\W	169.79	168.41	33	53	28	11	88	20	146	-	-	-
44H	44	B\W	177.87	176.5	33	53	28	11	88	20	154	-	-	-
45H	45	B\W	181.91	180.54	33	53	28	11	88	20	158	-	-	-
48H	48	B\W	194.04	192.67	33	53	28	11	88	20	171	-	-	-
50H	50	B\W	202.13	200.76	33	53	28	11	88	20	179	-	-	-
58H	58	B\W	234.47	233.09	33	53	28	11	88	20	211	-	-	-
60H	60	B\W	242.55	241.18	33	53	28	11	88	20	219	-	-	-
70H	70	B\W	282.98	281.61	33	60	28	11	88	25	258	-	-	-
72H	72	B\W	291.06	289.69	33	60	28	11	88	25	265	-	-	-
84H	84	B\W	339.57	338.2	33	60	28	11	100	25	314	-	-	-
96H	96	B\W	388.08	386.71	33	60	28	11	100	25	362	-	-	-
120H	120	B\W	485.1	483.73	33	60	28	11	100	25	460	-	-	-

▼ H型 同步带轮

H型齿形图:

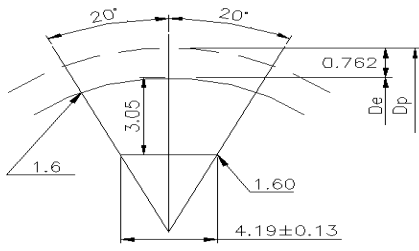

表示方法:

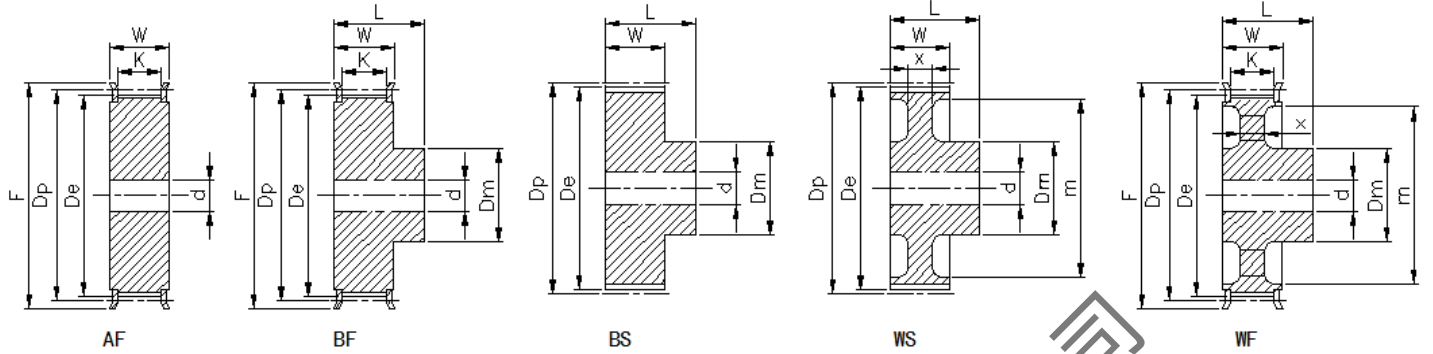
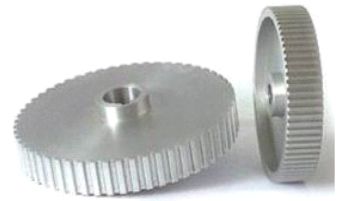
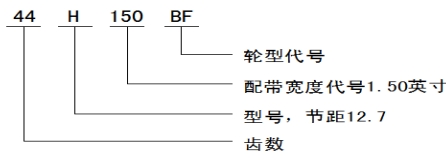

H型标准皮带宽150 (38.1mm)

规格	齿数	形状	节径	外径	W	L	K	X	轮毂直径	内孔	透孔外径	档边外径	档边内径	档边型号
14H	14	A\B	56.6	55.22	45	58	40	-	38	20	-	61	41	F-156141
15H	15	A\B	60.64	59.27	45	58	40	-	46	20	-	65	50	F-156550
16H	16	A\B	64.68	63.31	45	58	40	-	46	20	-	69	50	F-156950
18H	18	A\B	72.77	71.39	45	58	40	-	55	20	-	78	58	F-157858
19H	19	A\B	76.81	75.44	45	58	40	-	56	20	-	83	63	F-158363
20H	20	A\B	80.85	79.48	45	58	40	-	58	20	-	86	66	F-158666
21H	21	A\B	84.89	83.52	45	58	40	-	58	20	-	90	69	F-159069
22H	22	A\B	88.94	87.56	45	58	40	-	62	20	-	93	75	F-159375
24H	24	A\B	97.02	96.65	45	58	40	-	66	20	-	105	84	F-1510584
25H	25	A\B	101.06	99.69	45	58	40	-	70	20	-	108	84	F-1510884
26H	26	A\B	105.11	103.73	45	58	40	-	74	20	-	112	90	F-1511290
28H	28	A\B	113.19	111.82	45	58	40	-	74	20	-	118	90	F-1511890
30H	30	A\B	121.28	119.9	45	58	40	-	78	20	-	126	100	F-15126100
32H	32	A\B	129.3	127.99	45	58	40	-	82	20	-	136	118	F-15136118
34H	34	A\B	137.45	136.07	45	60	40	-	82	20	-	146	128	F-15146128
36H	36	A\B	145.53	144.16	45	60	40	-	82	20	-	152	134	F-15152134
38H	38	A\B	153.62	152.24	45	60	40	-	88	20	-	160	140	F-15160140
40H	40	A\B	161.7	160.33	45	60	40	-	88	20	-	170	150	F-15170150
42H	42	B\W	169.79	168.41	45	60	40	15	88	20	146	-	-	-
44H	44	B\W	177.87	176.5	45	60	40	15	88	20	154	-	-	-
45H	45	B\W	181.91	180.54	45	60	40	15	88	20	158	-	-	-
48H	48	B\W	194.04	192.67	45	60	40	15	88	20	171	-	-	-
50H	50	B\W	202.13	200.76	45	60	40	15	88	20	179	-	-	-
58H	58	B\W	234.47	233.09	45	60	40	15	88	20	211	-	-	-
60H	60	B\W	242.55	241.18	45	60	40	15	88	20	219	-	-	-
70H	70	B\W	282.98	281.61	45	65	40	15	88	25	258	-	-	-
72H	72	B\W	291.06	289.69	45	65	40	15	88	25	265	-	-	-
84H	84	B\W	339.57	338.2	45	65	40	15	100	25	314	-	-	-
96H	96	B\W	388.08	386.71	45	65	40	15	100	25	362	-	-	-
120H	120	B\W	485.1	483.73	45	65	40	15	100	25	460	-	-	-

H型齿形图:

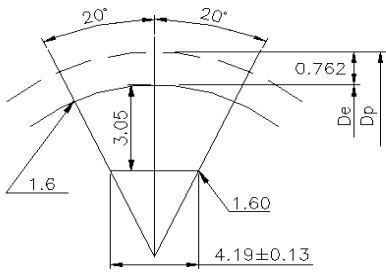

表示方法:

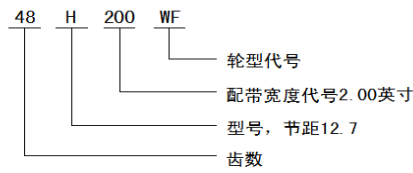

▼ H型 同步带轮

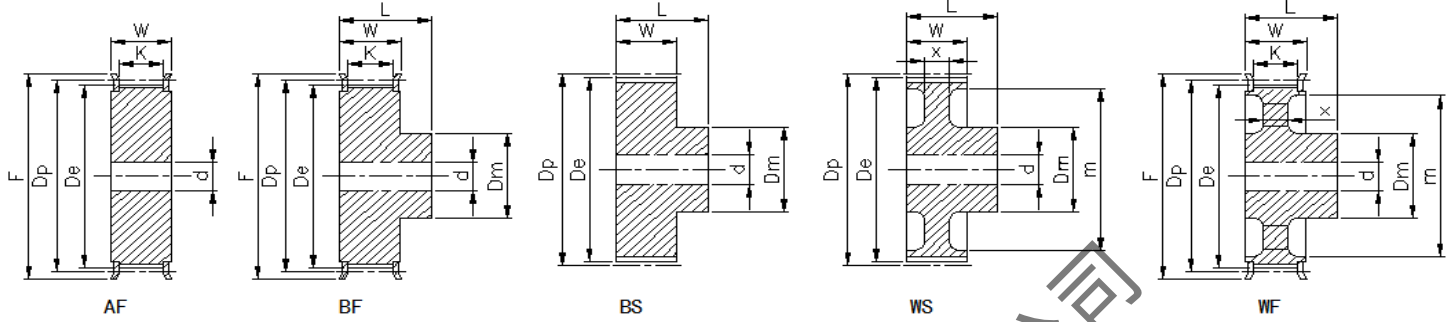
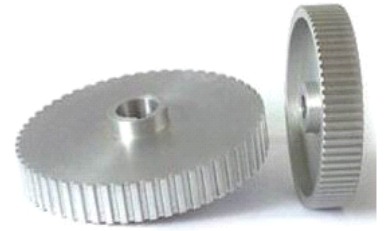

H型标准皮带宽200 (50.8mm)

规格	齿数	形状	节径	外径	W	L	K	X	轮毂直	内孔	透孔外	档边外	档边内	档边型号
14H	14	A\B	56.6	55.22	59	70	54	-	38	20	-	61	41	F-156141
15H	15	A\B	60.64	59.27	59	70	54	-	46	20	-	65	50	F-156550
16H	16	A\B	64.68	63.31	59	70	54	-	46	20	-	69	50	F-156950
18H	18	A\B	72.77	71.39	59	70	54	-	55	20	-	78	58	F-157858
19H	19	A\B	76.81	75.44	59	70	54	-	56	20	-	83	63	F-158363
20H	20	A\B	80.85	79.48	59	70	54	-	58	20	-	86	66	F-158666
21H	21	A\B	84.89	83.52	59	70	54	-	58	20	-	90	69	F-159069
22H	22	A\B	88.94	87.56	59	70	54	-	62	20	-	93	75	F-159375
24H	24	A\B	97.02	96.65	59	70	54	-	66	20	-	105	84	F-1510584
25H	25	A\B	101.06	99.69	59	70	54	-	70	20	-	108	84	F-1510884
26H	26	A\B	105.11	103.73	59	70	54	-	74	20	-	112	90	F-1511290
28H	28	A\B	113.19	111.82	59	70	54	-	74	20	-	118	90	F-1511890
30H	30	A\B	121.28	119.9	59	70	54	-	78	20	-	126	100	F-15126100
32H	32	A\B	129.3	127.99	59	70	54	-	82	20	-	136	118	F-15136118
34H	34	A\B	137.45	136.07	59	70	54	-	82	20	-	146	128	F-15146128
36H	36	A\B	145.53	144.16	59	70	54	-	82	20	-	152	134	F-15152134
38H	38	A\B	153.62	152.24	59	70	54	-	88	20	-	160	140	F-15160140
40H	40	A\B	161.7	160.33	59	70	54	-	88	20	-	170	150	F-15170150
42H	42	B\W	169.79	168.41	59	70	54	20	88	20	146	-	-	-
44H	44	B\W	177.87	176.5	59	70	54	20	88	20	154	-	-	-
45H	45	B\W	181.91	180.54	59	70	54	20	88	20	158	-	-	-
48H	48	B\W	194.04	192.67	59	70	54	20	88	20	171	-	-	-
50H	50	B\W	202.13	200.76	59	70	54	20	88	20	179	-	-	-
58H	58	B\W	234.47	233.09	59	70	54	20	88	20	211	-	-	-
60H	60	B\W	242.55	241.18	59	70	54	20	88	20	219	-	-	-
70H	70	B\W	282.98	281.61	59	70	54	20	88	25	258	-	-	-
72H	72	B\W	291.06	289.69	59	70	54	20	88	25	265	-	-	-
84H	84	B\W	339.57	338.2	59	70	54	20	100	25	314	-	-	-
96H	96	B\W	388.08	386.71	59	70	54	20	100	25	362	-	-	-
120H	120	B\W	485.1	483.73	59	70	54	20	100	25	460	-	-	-

XH型齿形图:

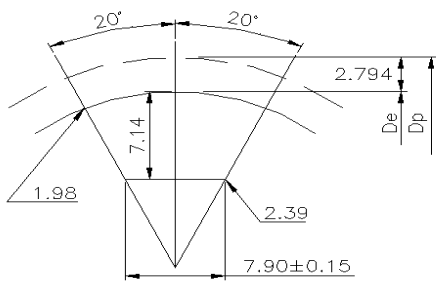

表示方法:

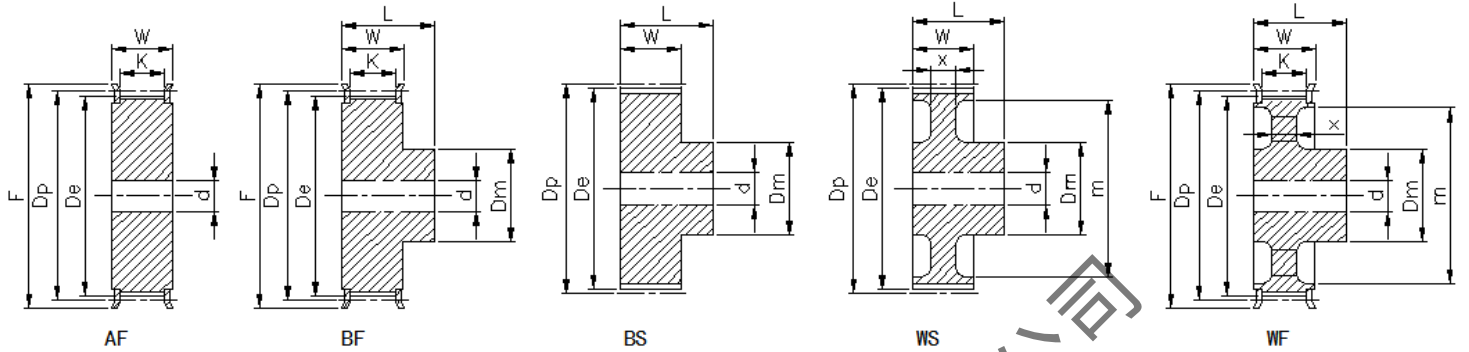
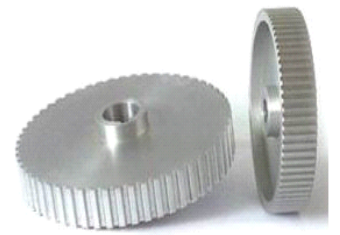
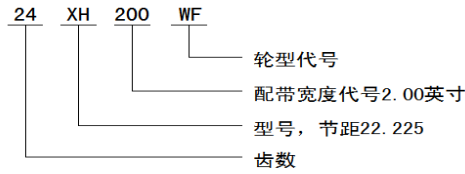

XH型标准皮带宽200 (50.8mm)

规格	齿数	形状	节径	外径	W	L	K	X	轮毂直径	内孔	透孔外径	档边外径	档边内径	档边型号
18H	18	A/B	127.34	124.55	67	85	57	-	80	28	-	141	84	F-4014184
19H	19	A/B	134.41	131.62	67	85	57	-	90	28	-	146	93	F-4014693
20H	20	A/B	141.49	138.69	67	85	57	-	90	28	-	155	98	F-4015598
21H	21	A/B	148.56	145.77	67	85	57	-	120	28	-	160	105	F-4016105
22H	22	A/B	155.64	152.84	67	85	57	-	100	28	-	169	112	F-40169112
23H	23	A/B	162.7	159.91	67	85	57	-	120	28	-	175	124	F-40175124
24H	24	A/B	169.79	166.99	67	85	57	-	120	28	-	183	126	F-40183126
25H	25	A/B	176.86	174.04	67	85	57	-	120	28	-	188	134	F-40188134
26H	26	A/B	183.93	181.14	67	85	57	-	120	28	-	197	141	F-40197141
27H	27	A/B	191.01	188.22	67	85	57	-	120	28	-	205	148	F-40205148
28H	28	A/B	198.09	195.29	67	85	57	-	150	28	-	211	155	F-40211155
30H	30	A/B	212.23	209.44	67	85	57	-	150	28	-	226	169	F-40226169
32H	32	B/W	226.38	223.59	67	85	57	23	150	30	173	-	-	-
34H	34	B/W	240.53	237.74	67	85	57	23	150	30	177	-	-	-
38H	38	B/W	268.83	266.03	67	85	57	23	150	30	216	-	-	-
40H	40	B/W	282.98	280.18	67	85	57	23	150	30	230	-	-	-
46H	46	B/W	325.42	322.63	67	97	57	23	175	30	272	-	-	-
48H	48	B/W	339.57	336.78	67	97	57	23	175	30	286	-	-	-
58H	58	B/W	410.32	407.52	67	97	57	23	175	30	357	-	-	-
60H	60	B/W	424.47	421.67	67	97	57	23	175	30	370	-	-	-
70H	70	B/W	495.21	492.42	67	97	57	23	175	30	442	-	-	-
72H	72	B/W	509.36	506.56	67	97	57	23	175	30	456	-	-	-
80H	80	B/W	565.95	563.16	67	97	57	23	175	30	513	-	-	-
84H	84	B/W	594.25	591.46	67	97	57	23	175	30	456	-	-	-
96H	96	B/W	679.15	676.35	67	97	57	23	175	30	626	-	-	-
120H	120	B/W	848.93	846.14	67	97	57	23	175	30	796	-	-	-

XH型齿形图:

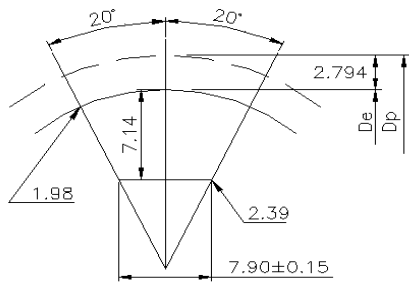

表示方法:

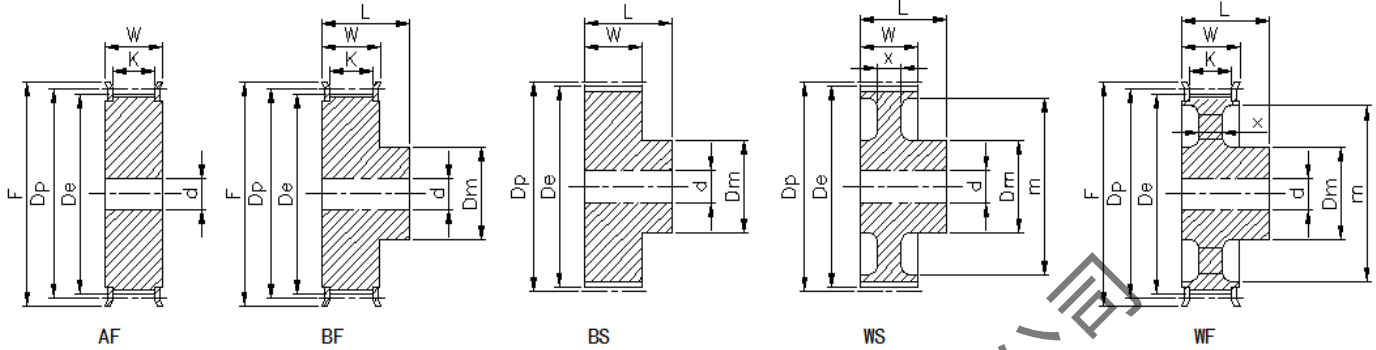
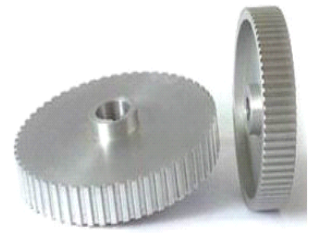
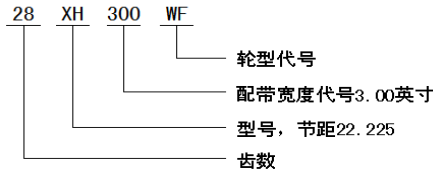

XH型标准皮带宽300 (76.2mm)

规格	齿数	形状	节径	外径	W	L	K	X	轮毂直	内孔	透孔外径	档边外	档边内径	档边型号
18H	18	A/B	127.34	124.55	94	110	84	-	80	28	-	141	84	F-4014184
19H	19	A/B	134.41	131.62	94	110	84	-	90	28	-	146	93	F-4014693
20H	20	A/B	141.49	138.69	94	110	84	-	90	28	-	155	98	F-4015598
21H	21	A/B	148.56	145.77	94	110	84	-	120	28	-	160	105	F-4016105
22H	22	A/B	155.64	152.84	94	110	84	-	100	28	-	169	112	F-40169112
23H	23	A/B	162.7	159.91	94	110	84	-	120	28	-	175	124	F-40175124
24H	24	A/B	169.79	166.99	94	110	84	-	120	28	-	183	126	F-40183126
25H	25	A/B	176.86	174.04	94	110	84	-	120	28	-	188	134	F-40188134
26H	26	A/B	183.93	181.14	94	110	84	-	120	28	-	197	141	F-40197141
27H	27	A/B	191.01	188.22	94	110	84	-	120	28	-	205	148	F-40205148
28H	28	A/B	198.09	195.29	94	110	84	-	150	28	-	211	155	F-40211155
30H	30	A/B	212.23	209.44	94	110	84	-	150	28	-	226	169	F-40226169
32H	32	B/W	226.38	223.59	94	110	84	31	150	30	173	-	-	-
34H	34	B/W	240.53	237.74	94	110	84	31	150	30	177	-	-	-
38H	38	B/W	268.83	266.03	94	110	84	31	150	30	216	-	-	-
40H	40	B/W	282.98	280.18	94	120	84	31	150	30	230	-	-	-
46H	46	B/W	325.42	322.63	94	120	84	31	175	30	272	-	-	-
48H	48	B/W	339.57	336.78	94	120	84	31	175	30	286	-	-	-
58H	58	B/W	410.32	407.52	94	120	84	31	175	30	357	-	-	-
60H	60	B/W	424.47	421.67	94	120	84	31	175	30	370	-	-	-
70H	70	B/W	495.21	492.42	94	120	84	31	175	30	442	-	-	-
72H	72	B/W	509.36	506.56	94	120	84	31	175	30	456	-	-	-
80H	80	B/W	565.95	563.16	94	120	84	31	175	30	513	-	-	-
84H	84	B/W	594.25	591.46	94	120	84	31	175	30	456	-	-	-
96H	96	B/W	679.15	676.35	94	120	84	31	175	30	626	-	-	-
120H	120	B/W	848.93	846.14	94	120	84	31	175	30	796	-	-	-

▼ XXH型 同步带轮

XXH型齿形图:

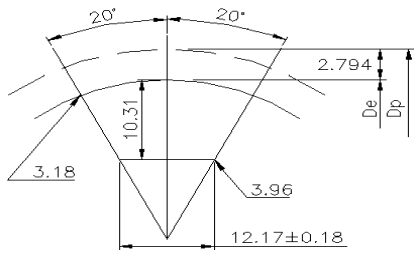

表示方法:

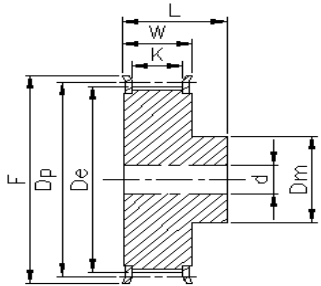
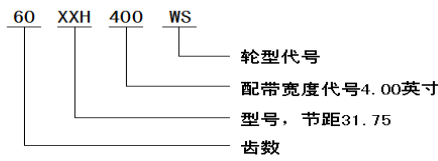

BF

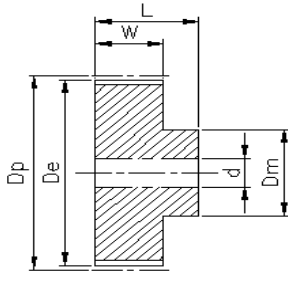

BS

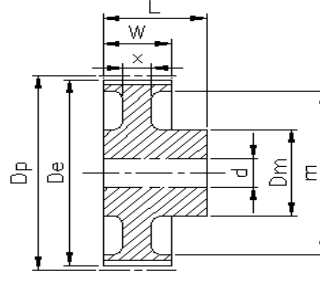

WS

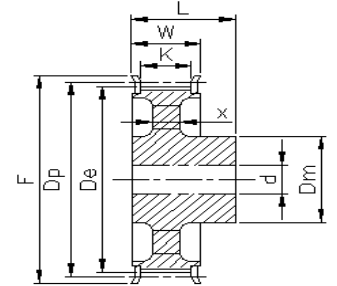

WF

XXH型标准皮带宽400 (101.6mm)

规格	齿数	形状	节径	外径	W	L	K	X	轮毂直	内孔	透孔外径	档边外	档边内径	档边型号
18XXH	18	B/W	181.91	178.87	121	140	111	-	120	28	-	198	140	F-50198140
19XXH	19	B/W	192.02	188.97	121	140	111	-	120	28	-	208	140	F-50208140
20XXH	20	B/W	202.13	199.08	121	140	111	-	130	28	-	208	150	F-50208150
21XXH	21	B/W	212.23	209.19	121	140	111	-	130	28	-	229	160	F-50239170
22XXH	22	B/W	222.34	219.29	121	140	111	-	130	28	-	239	170	
24XXH	24	B/W	242.55	239.5	121	140	111	45	150	28	190	-	-	-
25XXH	25	B/W	252.66	249.61	121	140	111	45	150	28	199	-	-	-
26XXH	26	B/W	262.76	259.72	121	140	111	45	150	28	209	-	-	-
27XXH	27	B/W	272.87	269.82	121	140	111	45	150	28	219	-	-	-
30XXH	30	B/W	313.19	300.14	121	140	111	45	150	28	250	-	-	-
40XXH	40	B/W	404.25	401.21	121	140	111	45	150	28	352	-	-	-
48XXH	48	B/W	485.1	482.06	121	140	111	45	175	30	432	-	-	-
60XXH	60	B/W	606.38	603.33	121	140	111	45	175	30	554	-	-	-
72XXH	72	B/W	727.66	724.61	121	140	111	45	175	35	675	-	-	-
90XXH	90	B/W	909.57	906.52	121	140	111	45	175	35	856	-	-	-

XXH型标准皮带宽500 (127mm)

规格	齿数	形状	节径	外径	W	L	K	X	轮毂直	内孔	透孔外径	档边外	档边内径	档边型号
18XXH	18	B/W	181.91	178.87	147	168	137	-	120	28	-	198	140	F-50198140
19XXH	19	B/W	192.02	188.97	147	168	137	-	120	28	-	208	140	F-50208140
20XXH	20	B/W	202.13	199.08	147	168	137	-	130	28	-	208	150	F-50208150
21XXH	21	B/W	212.23	209.19	147	168	137	-	130	28	-	229	160	F-50239170
22XXH	22	B/W	222.34	219.29	147	168	137	-	130	28	-	239	170	
24XXH	24	B/W	242.55	239.5	147	168	137	55	150	28	190	-	-	-
25XXH	25	B/W	252.66	249.61	147	168	137	55	150	28	199	-	-	-
26XXH	26	B/W	262.76	259.72	147	168	137	55	150	28	209	-	-	-
27XXH	27	B/W	272.87	269.82	147	168	137	55	150	28	219	-	-	-
30XXH	30	B/W	313.19	300.14	147	168	137	55	150	28	250	-	-	-
40XXH	40	B/W	404.25	401.21	147	168	137	55	150	28	352	-	-	-
48XXH	48	B/W	485.1	482.06	147	168	137	55	175	30	432	-	-	-
60XXH	60	B/W	606.38	603.33	147	168	137	55	175	30	554	-	-	-
72XXH	72	B/W	727.66	724.61	147	168	137	55	175	35	675	-	-	-
90XXH	90	B/W	909.57	906.52	147	168	137	55	175	35	856	-	-	-

T2.5型齿形图:

表示方法:

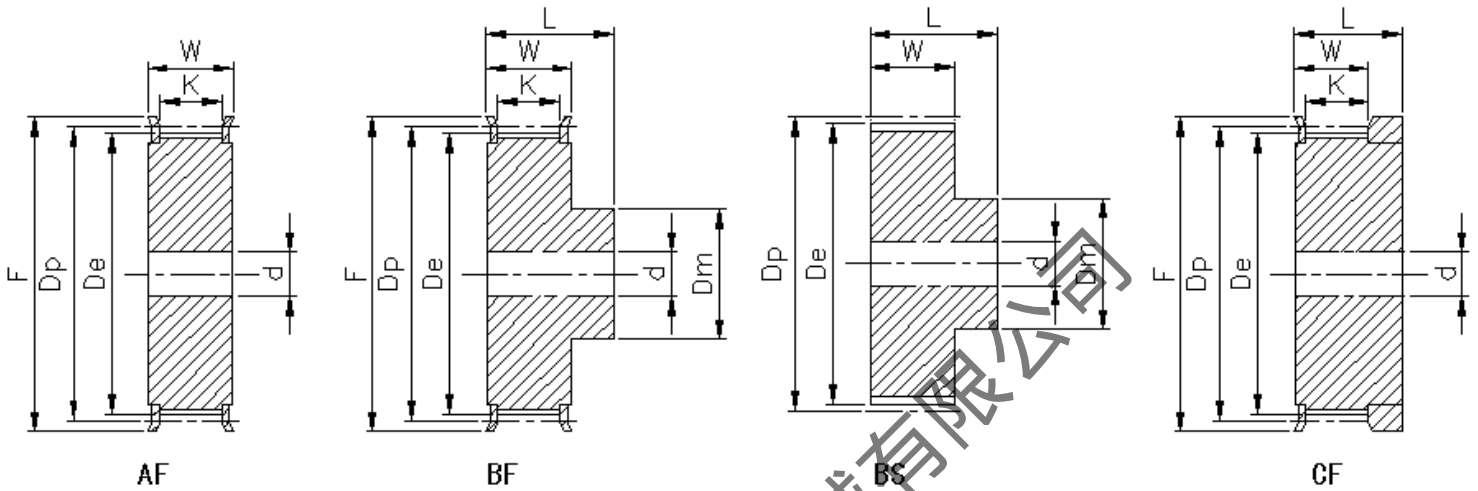
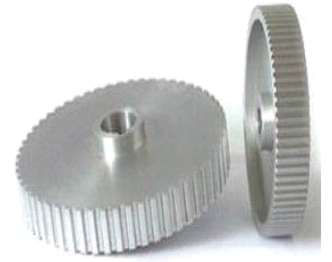
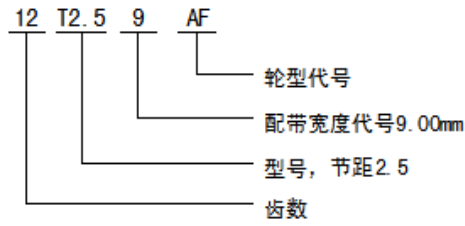
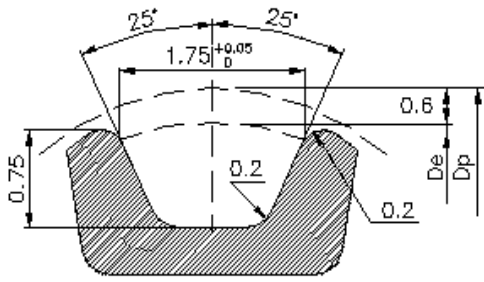

T2.5型标准皮带宽 (6mm)

规格	齿数	形状	节径	外径	W	L	K	透孔直径	轮毂直径	内孔	透孔外径	档边外径	档边内径	档边型号
T2.5	12	C\A	9.55	9.04	10	18	7	-	12	4	-	14	7	F-101407
T2.5	14	C\A	11.14	10.06	10	18	7	-	14	4	-	14	7	F-101407
T2.5	15	C\A	11.94	11.41	10	18	7	-	15	4	-	15	8	F-101508
T2.5	18	C\A	14.32	13.79	10	18	7	-	9	4	-	20	12	F-102012
T2.5	19	C\A	15.12	14.59	10	18	7	-	10	4	-	23	12	F-102312
T2.5	20	C\A	15.92	15.39	10	18	7	-	11	4	-	25	13	F-102513
T2.5	24	C\A	19.1	18.55	10	18	7	-	12	4	-	25	14	F-102514
T2.5	25	A\B	19.89	19.38	10	18	7	-	14	4	-	25	16	F-102516
T2.5	30	A\B	23.87	23.34	10	18	7	-	16	4	-	31	20	F-103120
T2.5	32	A\B	25.47	24.93	10	18	7	-	16	6	-	31	20	F-103120
T2.5	36	A\B	28.65	28.12	10	18	7	-	20	6	-	35	24	F-103524
T2.5	40	A\B	31.83	31.3	10	18	7	-	22	6	-	38	26	F-103826
T2.5	48	A\B	38.2	37.69	10	18	7	-	26	6	-	44	32	F-104432
T2.5	60	A\B	47.75	47.22	10	18	7	-	34	6	-	55	39	F-105539

▼ T5型 同步带轮

T5型齿形图:

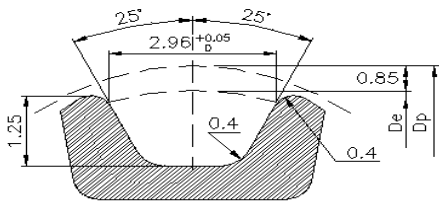

表示方法:

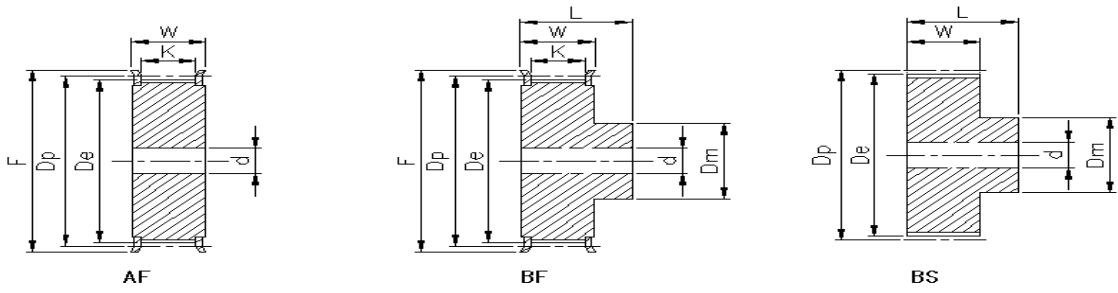
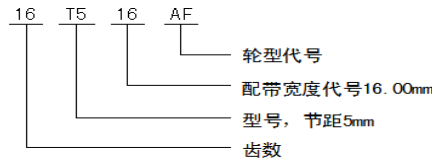

T5型标准皮带宽 (6mm)

规格	齿数	形状	节径	外径	W	L	K	X	轮毂直径	内孔	透孔外径	档边外径	档边内径	档边型号
T5	10	A/B	15.92	15.07	15	23	11	-	9	6	-	20	12	F-102012
T5	12	A/B	19.1	18.25	15	23	11	-	9	6	-	23	12	F-102312
T5	14	A/B	22.28	21.43	15	23	11	-	13	6	-	25	16	F-102516
T5	15	A/B	23.87	23.02	15	23	11	-	15	6	-	28	18	F-102818
T5	16	A/B	25.46	24.61	15	23	11	-	15	6	-	31	20	F-103120
T5	18	A/B	28.65	27.8	15	23	11	-	17	6	-	33	22	F-103322
T5	19	A/B	30.24	29.39	15	23	11	-	19	6	-	35	22	F-103522
T5	20	A/B	31.83	30.98	15	23	11	-	19	6	-	38	26	F-103826
T5	22	A/B	35.01	34.16	15	23	11	-	25	6	-	41	28	F-104128
T5	24	A/B	38.2	37.35	15	23	11	-	25	6	-	43	28	F-104328
T5	25	A/B	39.79	38.94	15	23	11	-	25	6	-	43	28	F-104328
T5	26	A/B	41.36	40.53	15	23	11	-	30	6	-	47	34	F-104734
T5	27	A/B	42.97	42.12	15	23	11	-	30	6	-	48	36	F-104836
T5	28	A/B	44.56	43.71	15	23	11	-	30	8	-	48	36	F-104836
T5	30	A/B	47.75	46.9	15	23	11	-	30	8	-	51	36	F-104836
T5	32	A/B	50.93	50.08	15	23	11	-	35	8	-	54	42	F-105442
T5	36	A/B	57.3	56.45	15	23	11	-	35	8	-	61	41	F-106141
T5	40	A/B	63.66	62.81	15	23	11	-	45	8	-	69	50	F-106950
T5	42	A/B	66.85	66	15	23	11	-	45	8	-	74	53	F-107453
T5	44	A/B	70.03	69.18	15	23	11	-	45	8	-	74	53	F-107454
T5	48	A/B	76.39	75.54	15	23	11	-	50	8	-	83	63	F-108363
T5	50	A/B	79.58	78.73	15	23	11	-	50	8	-	86	66	F-108666
T5	60	A/B	95.49	94.64	15	23	11	-	60	8	-	99	78	F-109978

T5型标准皮带宽 (16mm)

规格	齿数	形状	节径	外径	W	L	K	X	轮毂直径	内孔	透孔外径	档边外径	档边内径	档边型号
T5	10	A/B	15.92	15.07	21	30	17	-	9	6	-	20	12	F-102012
T5	12	A/B	19.1	18.25	21	30	17	-	9	6	-	23	12	F-102312
T5	14	A/B	22.28	21.43	21	30	17	-	13	6	-	25	16	F-102516
T5	15	A/B	23.87	23.02	21	30	17	-	15	6	-	28	18	F-102818
T5	16	A/B	25.46	24.61	21	30	17	-	15	6	-	31	20	F-103120
T5	18	A/B	28.65	27.8	21	30	17	-	17	6	-	33	22	F-103322
T5	19	A/B	30.24	29.39	21	30	17	-	19	6	-	35	22	F-103522
T5	20	A/B	31.83	30.98	21	30	17	-	19	6	-	38	26	F-103826
T5	22	A/B	35.01	34.16	21	30	17	-	25	6	-	41	28	F-104128
T5	24	A/B	38.2	37.35	21	30	17	-	25	6	-	43	28	F-104328
T5	25	A/B	39.79	38.94	21	30	17	-	25	6	-	43	28	F-104328
T5	26	A/B	41.36	40.53	21	30	17	-	30	6	-	47	34	F-104734
T5	27	A/B	42.97	42.12	21	30	17	-	30	6	-	48	36	F-104836
T5	28	A/B	44.56	43.71	21	30	17	-	30	8	-	48	36	F-104836
T5	30	A/B	47.75	46.9	21	30	17	-	30	8	-	51	36	F-104836
T5	32	A/B	50.93	50.08	21	30	17	-	35	8	-	54	42	F-105442
T5	36	A/B	57.3	56.45	21	30	17	-	35	8	-	61	41	F-106141
T5	40	A/B	63.66	62.81	21	30	17	-	45	8	-	69	50	F-106950
T5	42	A/B	66.85	66	21	30	17	-	45	8	-	74	53	F-107453
T5	44	A/B	70.03	69.18	21	30	17	-	45	8	-	74	53	F-107454
T5	48	A/B	76.39	75.54	21	30	17	-	50	8	-	83	63	F-108363
T5	50	A/B	79.58	78.73	21	30	17	-	50	8	-	86	66	F-108666
T5	60	A/B	95.49	94.64	21	30	17	-	60	8	-	99	78	F-109978

T5型齿形图:

表示方法:

▼ T5型 同步带轮

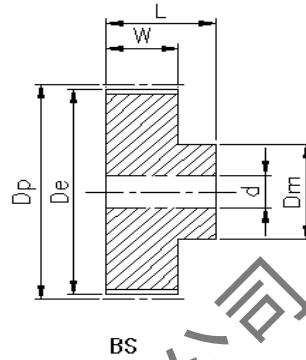
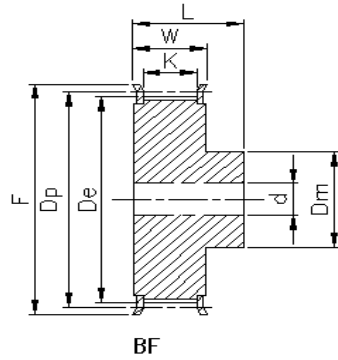
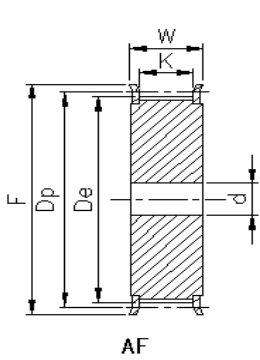
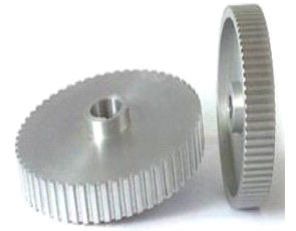
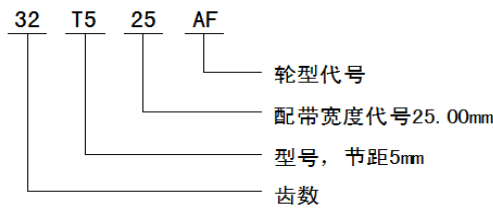
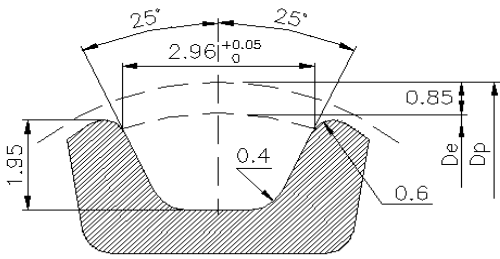

T5型标准皮带宽 (25mm)

规格	齿数	形状	节径	外径	W	L	K	X	轮毂直径	内孔	透孔外径	档边外径	档边内径	档边型号
T5	10	A/B	15.92	15.07	30	42	26	-	9	6	-	20	12	F-102012
T5	12	A/B	19.1	18.25	30	42	26	-	9	6	-	23	12	F-102312
T5	14	A/B	22.28	21.43	30	42	26	-	13	6	-	25	16	F-102516
T5	15	A/B	23.87	23.02	30	42	26	-	15	6	-	28	18	F-102818
T5	16	A/B	25.46	24.61	30	42	26	-	15	6	-	31	20	F-103120
T5	18	A/B	28.65	27.8	30	42	26	-	17	6	-	33	22	F-103322
T5	19	A/B	30.24	29.39	30	42	26	-	19	6	-	35	22	F-103522
T5	20	A/B	31.83	30.98	30	42	26	-	19	6	-	38	26	F-103826
T5	22	A/B	35.01	34.16	30	42	26	-	25	6	-	41	28	F-104128
T5	24	A/B	38.2	37.35	30	42	26	-	25	6	-	43	28	F-104328
T5	25	A/B	39.79	38.94	30	42	26	-	25	6	-	43	28	F-104328
T5	26	A/B	41.36	40.53	30	42	26	-	30	6	-	47	34	F-104734
T5	27	A/B	42.97	42.12	30	42	26	-	30	6	-	48	36	F-104836
T5	28	A/B	44.56	43.71	30	42	26	-	30	8	-	48	36	F-104836
T5	30	A/B	47.75	46.9	30	42	26	-	30	8	-	51	36	F-104836
T5	32	A/B	50.93	50.08	30	42	26	-	35	8	-	54	42	F-105442
T5	36	A/B	57.3	56.45	30	42	26	-	35	8	-	61	41	F-106141
T5	40	A/B	63.66	62.81	30	42	26	-	45	8	-	69	50	F-106950
T5	42	A/B	66.85	66	30	42	26	-	45	8	-	74	53	F-107453
T5	44	A/B	70.03	69.18	30	42	26	-	45	8	-	74	53	F-107454
T5	48	A/B	76.39	75.54	30	42	26	-	50	8	-	83	63	F-108363
T5	50	A/B	79.58	78.73	30	42	26	-	50	8	-	86	66	F-108666
T5	60	A/B	95.49	94.64	30	42	26	-	60	8	-	99	78	F-109978

T10型齿形图:

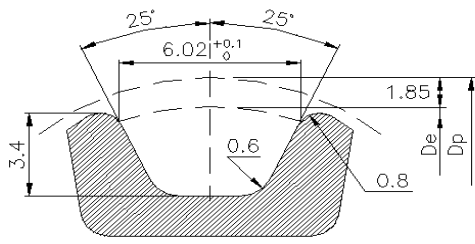

表示方法:

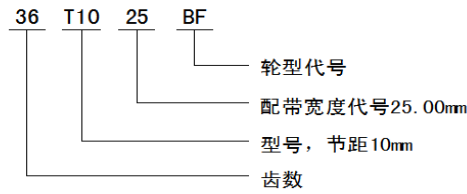

▼ T10型 同步带轮

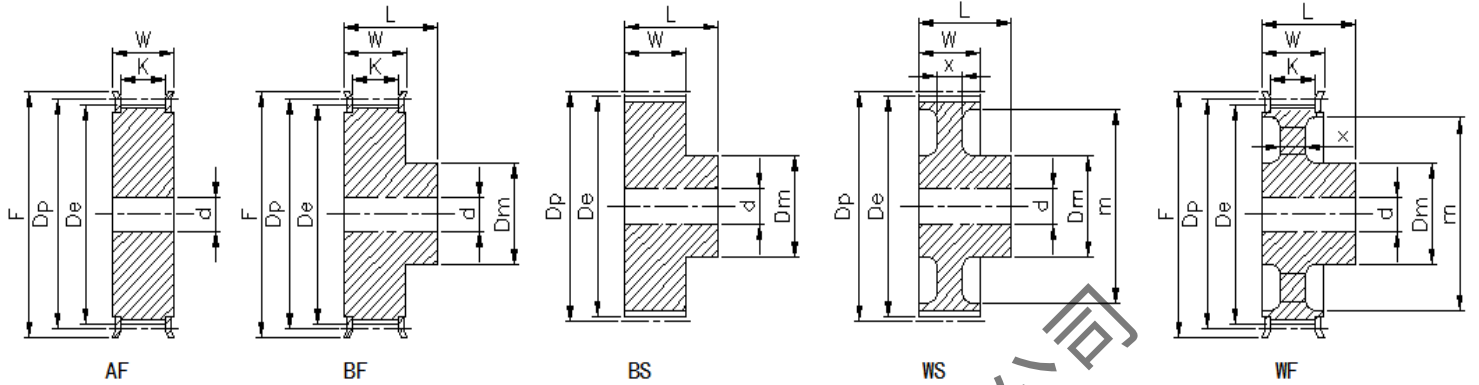
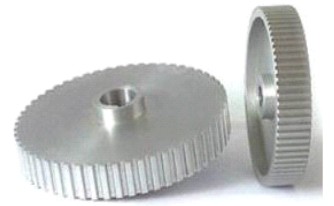

T10型标准皮带宽 (25mm)

规格	齿数	形状	节径	外径	W	L	K	X	轮毂直径	内孔	透孔外径	档边外径	档边内径	档边型号
T10	12	A/B	38.2	36.35	32	42	27	-	25	10	-	43	28	F-154328
T10	14	A/B	44.56	42.07	32	42	27	-	30	10	-	47	34	F-154734
T10	15	A/B	47.75	45.9	32	42	27	-	33	10	-	51	36	F-155136
T10	16	A/B	50.93	49.05	32	42	27	-	35	10	-	57	41	F-156741
T10	18	A/B	57.3	55.45	32	42	27	-	37	12	-	61	41	F-156141
T10	20	A/B	63.66	61.8	32	42	27	-	40	12	-	69	50	F-156950
T10	22	A/B	70.03	68.15	32	42	27	-	40	12	-	74	53	F-157453
T10	24	A/B	76.39	74.55	32	42	27	-	40	12	-	83	63	F-158363
T10	25	A/B	79.58	77.73	32	42	27	-	40	12	-	86	66	F-158666
T10	26	A/B	82.76	80.9	32	42	27	-	45	12	-	86	66	F-158666
T10	28	A/B	89.13	87.28	32	42	27	-	45	12	-	93	75	F-159375
T10	30	A/B	95.49	93.65	32	42	27	-	45	12	-	99	78	F-159978
T10	32	A/B	101.86	100	32	42	27	-	50	14	-	105	84	F-1510584
T10	36	A/B	114.59	112.75	32	42	27	-	50	14	-	118	90	F-1511890
T10	40	A/B	127.32	125.45	32	42	27	-	50	14	-	131	111	F-15131111
T10	44	B/W	140.06	138.2	32	42	27	11	55	16	120	-	-	-
T10	48	B/W	152.79	150.9	32	42	27	11	55	16	132	-	-	-
T10	50	B/W	159.15	157.3	32	42	27	11	60	16	140	-	-	-
T10	60	B/W	190.99	189.14	32	42	27	11	60	16	170	-	-	-

▼ T10型 同步带轮

T10型齿形图:

表示方法:

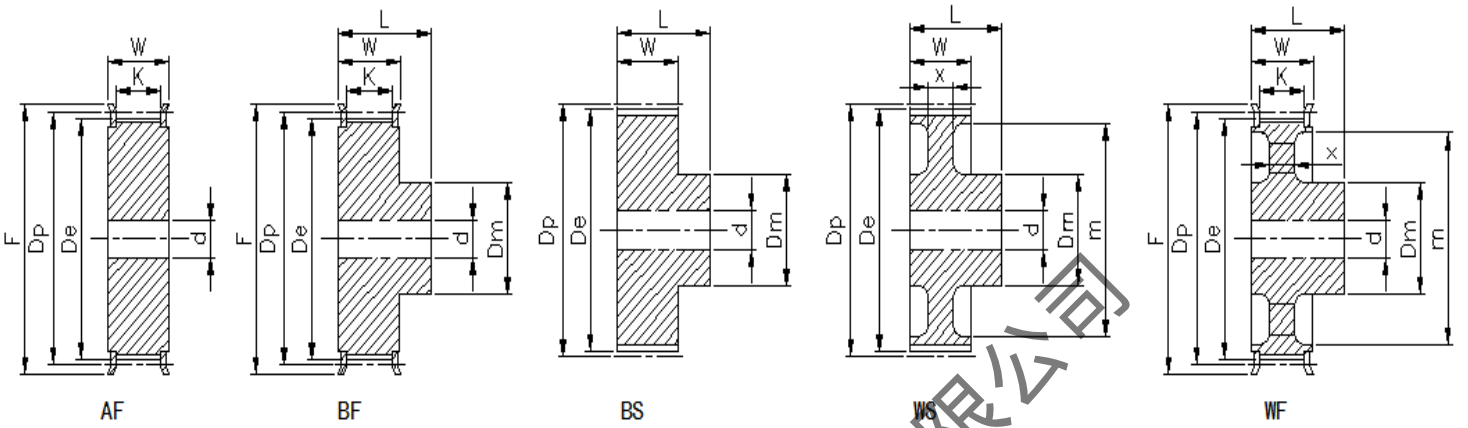
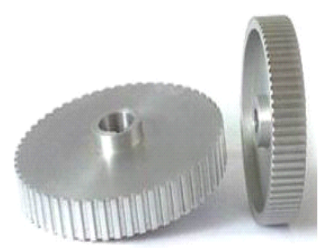
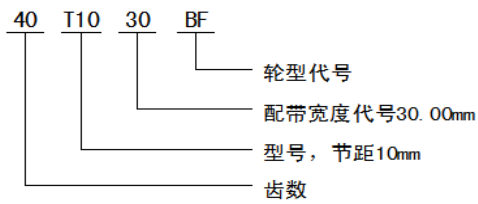
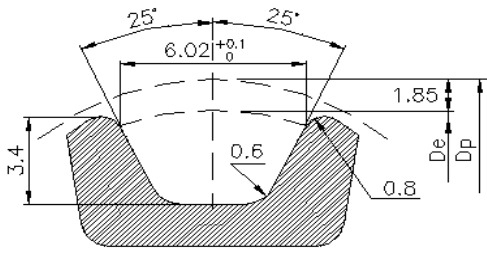

T10型标准皮带宽 (30mm)

规格	齿数	形状	节径	外径	W	L	K	X	轮毂直径	内孔	透孔外径	档边外径	档边内径	档边型号
T10	12	A/B	38.2	36.35	37	47	32	-	25	10	-	43	28	F-154328
T10	14	A/B	44.56	42.07	37	47	32	-	30	10	-	47	34	F-154734
T10	15	A/B	47.75	45.9	37	47	32	-	33	10	-	51	36	F-155136
T10	16	A/B	50.93	49.05	37	47	32	-	35	10	-	57	41	F-156741
T10	18	A/B	57.3	55.45	37	47	32	-	37	12	-	61	41	F-156141
T10	20	A/B	63.66	61.8	37	47	32	-	40	12	-	69	50	F-156950
T10	22	A/B	70.03	68.15	37	47	32	-	40	12	-	74	53	F-157453
T10	24	A/B	76.39	74.55	37	47	32	-	40	12	-	83	63	F-158363
T10	25	A/B	79.58	77.73	37	47	32	-	40	12	-	86	66	F-158666
T10	26	A/B	82.76	80.9	37	47	32	-	45	12	-	86	66	F-158666
T10	28	A/B	89.13	87.28	37	47	32	-	45	12	-	93	75	F-159375
T10	30	A/B	95.49	93.65	37	47	32	-	45	12	-	99	78	F-159978
T10	32	A/B	101.86	100	37	47	32	-	50	14	-	105	84	F-1510584
T10	36	A/B	114.59	112.75	37	47	32	-	50	14	-	118	90	F-1511890
T10	40	A/B	127.32	125.45	37	47	32	-	50	14	-	131	111	F-15131111
T10	44	B/W	140.06	138.2	37	47	32	13	55	16	120	-	-	-
T10	48	B/W	152.79	150.9	37	47	32	13	55	16	132	-	-	-
T10	50	B/W	159.15	157.3	37	47	32	13	60	16	140	-	-	-
T10	60	B/W	190.99	189.14	37	47	32	13	60	16	170	-	-	-

T10型齿形图:

表示方法:

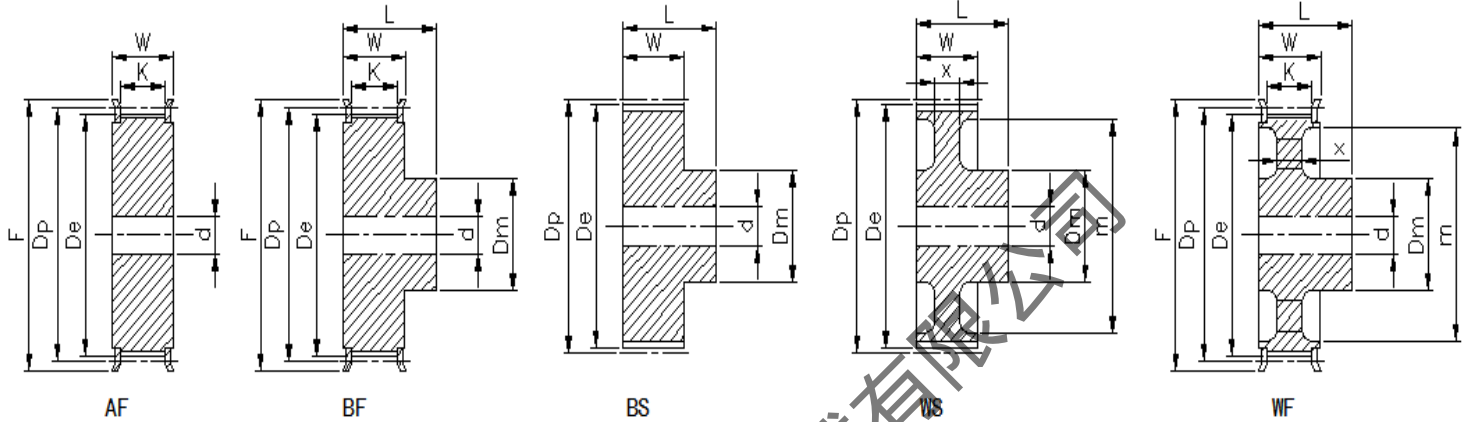
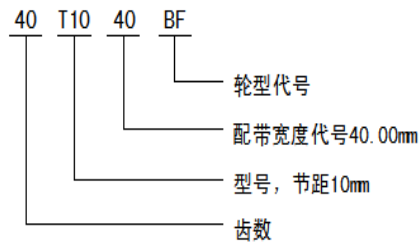
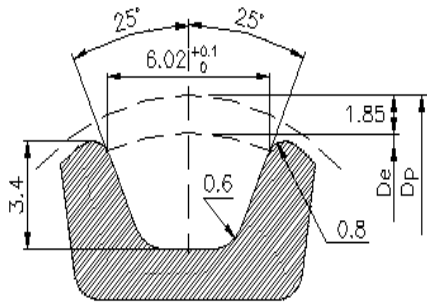

T10型标准皮带宽 (40mm)													
规格	齿数	形状	节径	外径	W	L	K	轮毂直径	内孔	透孔外径	档边外径	档边内径	档边型号
T10	12	A/B	38.2	36.35	47	57	42	25	10	-	43	28	F-154328
T10	14	A/B	44.56	42.07	47	57	42	30	10	-	47	34	F-154734
T10	15	A/B	47.75	45.9	47	57	42	33	10	-	51	36	F-155136
T10	16	A/B	50.93	49.05	47	57	42	35	10	-	57	41	F-156741
T10	18	A/B	57.3	55.45	47	57	42	37	12	-	61	41	F-156141
T10	20	A/B	63.66	61.8	47	57	42	40	12	-	69	50	F-156950
T10	22	A/B	70.03	68.15	47	57	42	40	12	-	74	53	F-157453
T10	24	A/B	76.39	74.55	47	57	42	40	12	-	83	63	F-158363
T10	25	A/B	79.58	77.73	47	57	42	40	12	-	86	66	F-158666
T10	26	A/B	82.76	80.9	47	57	42	45	12	-	86	66	F-158666
T10	28	A/B	89.13	87.28	47	57	42	45	12	-	93	75	F-159375
T10	30	A/B	95.49	93.65	47	57	42	45	12	-	99	78	F-159978
T10	32	A/B	101.86	100	47	57	42	50	14	-	105	84	F-1510584
T10	36	A/B	114.59	112.75	47	57	42	50	14	-	118	90	F-1511890
T10	40	A/B	127.32	125.45	47	57	42	50	14	-	131	111	F-15131111
T10	44	B/W	140.06	138.2	47	57	42	15	55	16	120	-	-
T10	48	B/W	152.79	150.9	47	57	42	15	55	16	132	-	-
T10	50	B/W	159.15	157.3	47	57	42	15	60	16	140	-	-
T10	60	B/W	190.99	189.14	47	57	42	15	60	16	170	-	-

T10型齿形图:

表示方法:

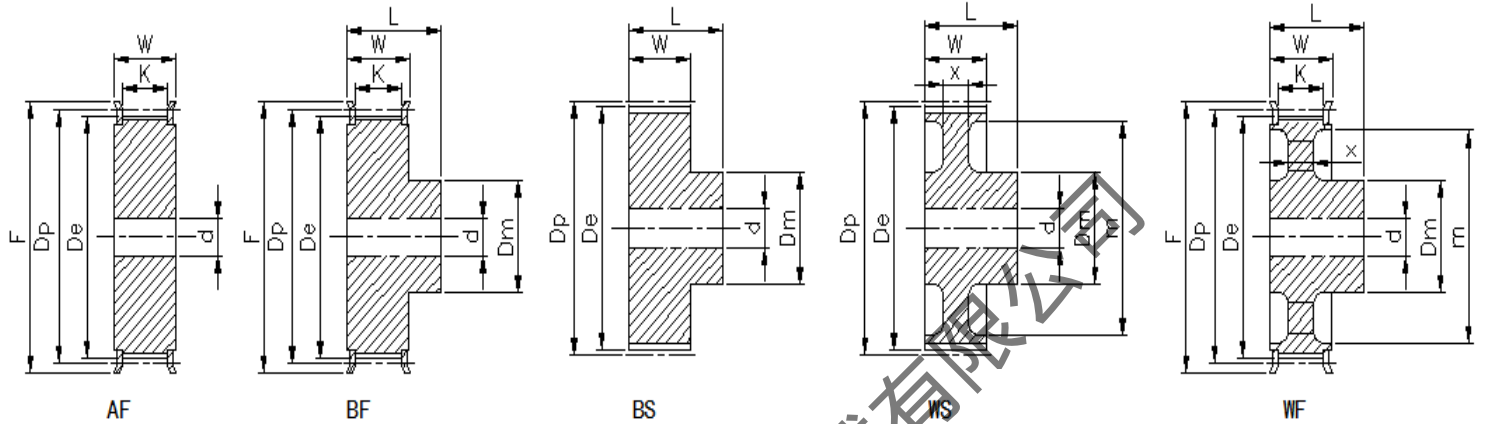
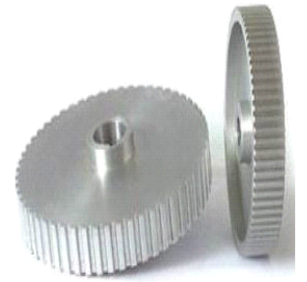
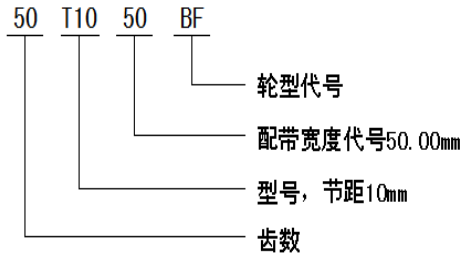
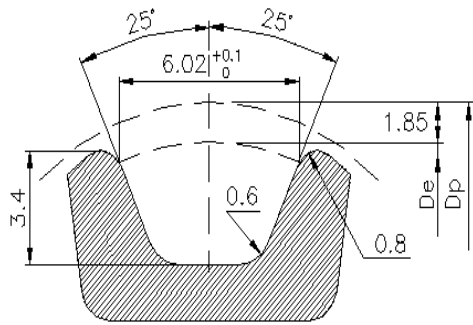

T10型标准皮带宽 (50mm)

规格	齿数	形状	节径	外径	W	L	K	轮毂直径	内孔	透孔外径	档边外径	档边内径	档边型号
T10	12	A/B	38.2	36.35	57	67	52	25	10	-	43	28	F-154328
T10	14	A/B	44.56	42.07	57	67	52	30	10	-	47	34	F-154734
T10	15	A/B	47.75	45.9	57	67	52	33	10	-	51	36	F-155136
T10	16	A/B	50.93	49.05	57	67	52	35	10	-	57	41	F-156741
T10	18	A/B	57.3	55.45	57	67	52	37	12	-	61	41	F-156141
T10	20	A/B	63.66	61.8	57	67	52	40	12	-	69	50	F-156950
T10	22	A/B	70.03	68.15	57	67	52	40	12	-	74	53	F-157453
T10	24	A/B	76.39	74.55	57	67	52	40	12	-	83	63	F-158363
T10	25	A/B	79.58	77.73	57	67	52	40	12	-	86	66	F-158666
T10	26	A/B	82.76	80.9	57	67	52	45	12	-	86	66	F-158666
T10	28	A/B	89.13	87.28	57	67	52	45	12	-	93	75	F-159375
T10	30	A/B	95.49	93.65	57	67	52	45	12	-	99	78	F-159978
T10	32	A/B	101.86	100	57	67	52	50	14	-	105	84	F-1510584
T10	36	A/B	114.59	112.75	57	67	52	50	14	-	118	90	F-1511890
T10	40	A/B	127.32	125.45	57	67	52	50	14	-	131	111	F-15131111
T10	44	B/W	140.06	138.2	57	67	52	18	55	16	120	-	-
T10	48	B/W	152.79	150.9	57	76	52	18	55	16	132	-	-
T10	50	B/W	159.15	157.3	57	67	52	18	60	16	140	-	-
T10	60	B/W	190.99	189.14	57	67	52	18	60	16	170	-	-

T20型齿形图:

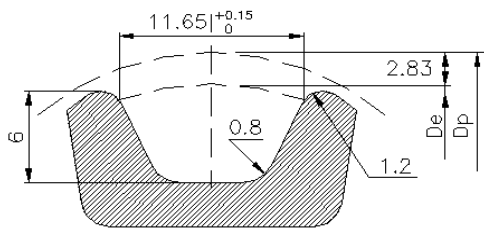

表示方法:

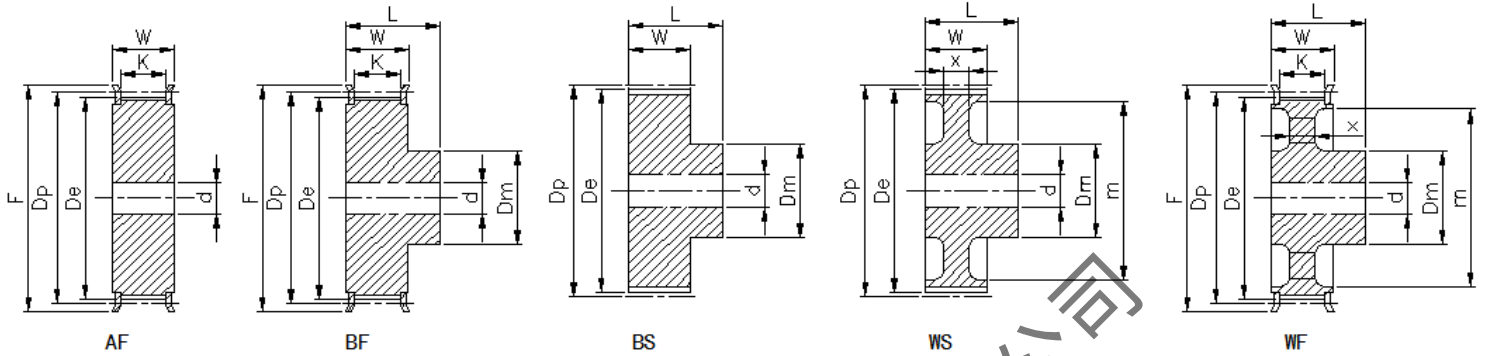
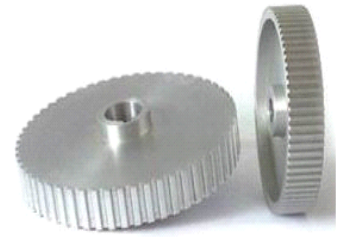
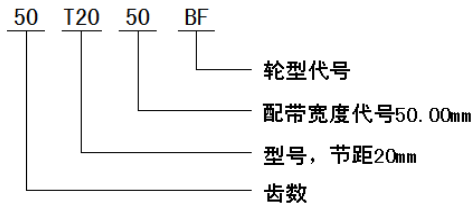

T20型标准皮带宽 (50mm)

规格	齿数	形状	节径	外径	W	L	K	X	轮毂直径	内孔	透孔外径	档边外径	档边内径	档边型号
T20	18	A/B	114.59	111.76	65	73	56	-	60	24	-	120	80	F-4012080
T20	19	A/B	120.96	118.13	65	73	56	-	60	24	-	130	80	F-4013080
T20	20	A/B	127.35	124.49	65	73	56	-	80	24	-	136	90	F-4013690
T20	21	A/B	133.69	130.86	65	73	56	-	80	24	-	142	92	F-4014292
T20	22	A/B	140.06	137.23	65	73	56	-	80	24	-	150	100	F-40150100
T20	23	A/B	146.42	143.59	65	73	56	-	95	24	-	156	108	F-40156108
T20	24	A/B	152.79	149.96	65	73	56	-	95	24	-	158	112	F-40158112
T20	25	A/B	159.15	156.32	65	73	56	-	95	24	-	168	120	F-40168120
T20	26	A/B	165.52	162.69	65	73	56	-	95	24	-	175	126	F-40175126
T20	27	A/B	171.89	169.06	65	73	56	-	95	24	-	181	134	F-40181134
T20	28	A/B	178.25	175.42	65	73	56	-	110	24	-	187	140	F-40187140
T20	29	A/B	184.62	181.79	65	73	56	-	110	24	-	194	145	F-40194145
T20	30	A/B	190.99	188.16	65	73	56	-	110	24	-	200	152	F-40200152
T20	32	W	203.72	200.89	65	73	56	20	110	24	160	-	-	-
T20	34	W	216.45	213.62	65	73	56	20	110	24	174	-	-	-
T20	36	W	229.18	226.35	65	73	56	20	110	32	186	-	-	-
T20	38	W	241.92	239.09	65	73	56	20	110	32	199	-	-	-
T20	40	W	254.65	251.82	65	73	56	20	110	32	212	-	-	-
T20	42	W	267.38	264.55	65	73	56	20	130	32	224	-	-	-
T20	44	W	280.11	277.28	65	73	56	20	130	32	238	-	-	-
T20	46	W	292.85	290.02	65	73	56	20	130	32	250	-	-	-
T20	48	W	305.58	302.75	65	73	56	20	130	32	262	-	-	-
T20	50	W	318.31	315.48	65	73	56	20	130	32	275	-	-	-
T20	60	W	381.97	379.14	65	73	56	20	130	32	340	-	-	-
T20	72	W	458.37	455.54	65	73	56	20	140	32	415	-	-	-

▼ T20型 同步带轮

T20型齿形图:

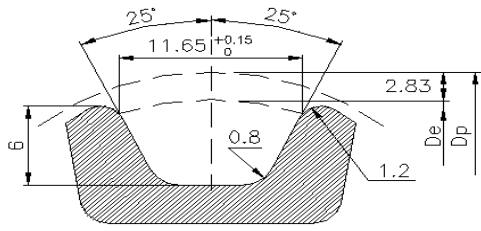

表示方法:

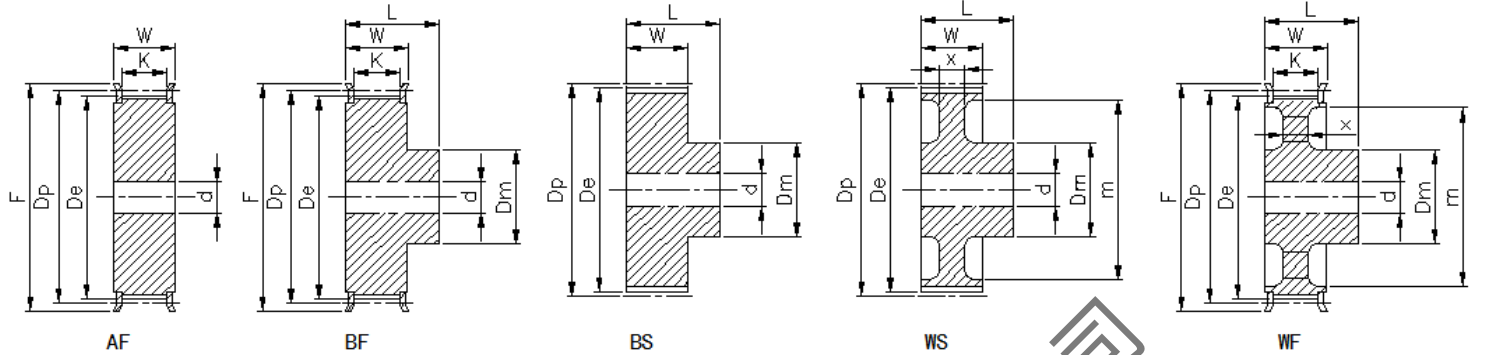
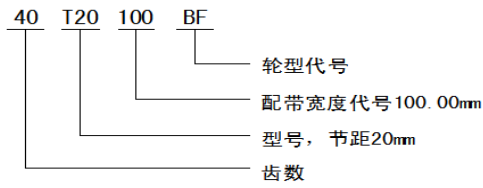

T20型标准皮带宽 (100mm)

规格	齿数	形状	节径	外径	W	L	K	X	轮毂直径	内孔	透孔外径	档边外径	档边内径	档边型号
T20	18	A/B	114.59	111.76	115	123	105	-	60	24	-	120	80	F-4012080
T20	19	A/B	120.96	118.13	115	123	105	-	60	24	-	130	80	F-4013080
T20	20	A/B	127.35	124.49	115	123	105	-	80	24	-	136	90	F-4013690
T20	21	A/B	133.69	130.86	115	123	105	-	80	24	-	142	92	F-4014292
T20	22	A/B	140.06	137.23	115	123	105	-	80	24	-	150	100	F-40150100
T20	23	A/B	146.42	143.59	115	123	105	-	95	24	-	156	108	F-40156108
T20	24	A/B	152.79	149.96	115	123	105	-	95	24	-	158	112	F-40158112
T20	25	A/B	159.15	156.32	115	123	105	-	95	24	-	168	120	F-40168120
T20	26	A/B	165.52	162.69	115	123	105	-	95	24	-	175	126	F-40175126
T20	27	A/B	171.89	169.06	115	123	105	-	95	24	-	181	134	F-40181134
T20	28	A/B	178.25	175.42	115	123	105	-	110	24	-	187	140	F-40187140
T20	29	A/B	184.62	181.79	115	123	105	-	110	24	-	194	145	F-40194145
T20	30	A/B	190.99	188.16	115	123	105	-	110	24	-	200	152	F-40200152
T20	32	W	203.72	200.89	115	123	105	37	110	24	160	-	-	-
T20	34	W	216.45	213.62	115	123	105	37	110	24	174	-	-	-
T20	36	W	229.18	226.35	115	123	105	37	110	32	186	-	-	-
T20	38	W	241.92	239.09	115	123	105	37	110	32	199	-	-	-
T20	40	W	254.65	251.82	115	123	105	37	110	32	212	-	-	-
T20	42	W	267.38	264.55	115	123	105	37	130	32	224	-	-	-
T20	44	W	280.11	277.28	115	123	105	37	130	32	238	-	-	-
T20	46	W	292.85	290.02	115	123	105	37	130	32	250	-	-	-
T20	48	W	305.58	302.75	115	123	105	37	130	32	262	-	-	-
T20	50	W	318.31	315.48	115	123	105	37	130	32	275	-	-	-
T20	60	W	381.97	379.14	115	123	105	37	130	32	340	-	-	-
T20	72	W	458.37	455.54	115	123	105	37	140	32	415	-	-	-

3M型齿形图:

表示方法:

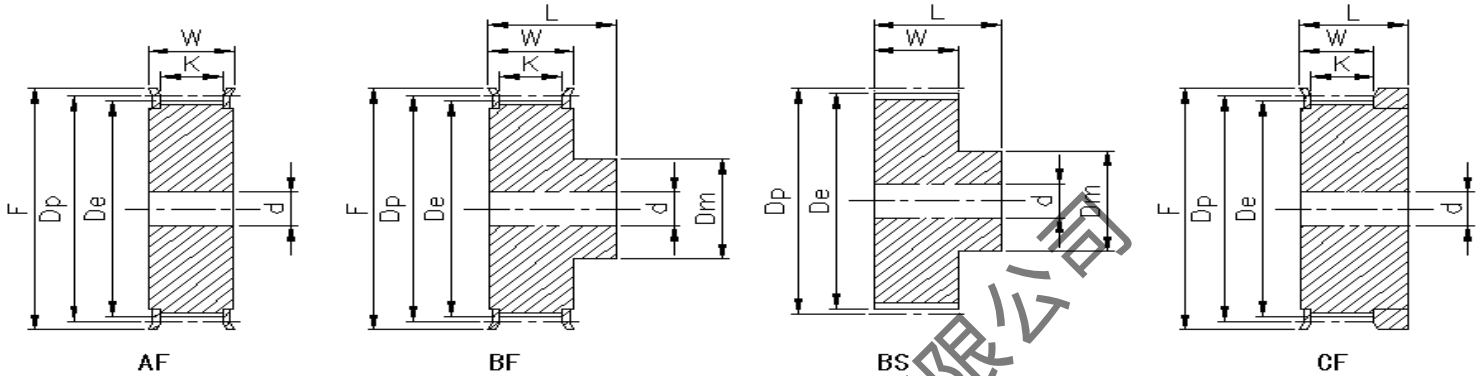
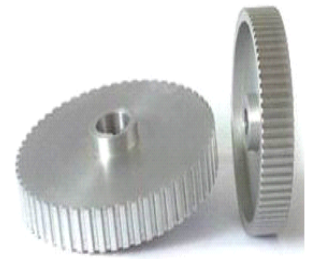
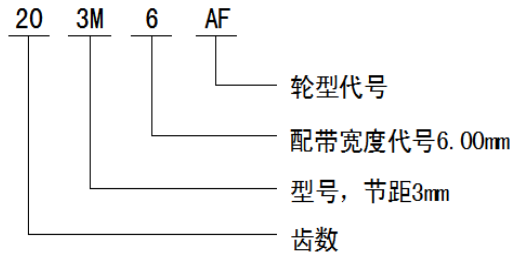
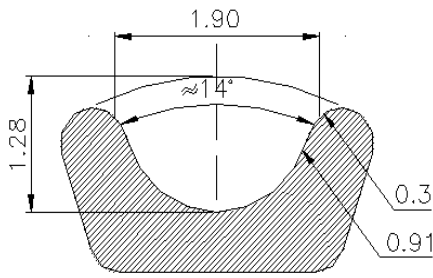

3M型标准皮带宽6mm

规格	齿数	形状	节径	外径	W	L	1K	X	轮毂直径	内孔	透孔外径	档边外径	档边内径	档边型号
3M	10	C/A	9.55	8.79	11	19	7	-	-	3	-	13	6	F-101306
3M	11	C/A	10.5	9.74	11	19	7	-	-	3	-	14	7	F-101407
3M	12	C/A	11.46	10.7	11	19	7	-	-	3	-	14	7	F-101407
3M	14	C/A	13.37	12.61	11	19	7	-	-	4	-	13	9.5	F-101695
3M	15	C/A	14.32	13.56	11	19	7	-	-	4	-	18	11	F-101811
3M	16	C/A	15.28	14.52	11	19	7	-	10	4	-	18	11	F-101811
3M	18	C/A	17.19	16.43	11	19	7	-	10	5	-	23	12	F-102312
3M	19	C/A	18.14	17.38	11	19	7	-	10	5	-	25	13	F-102513
3M	20	C/A	19.1	18.34	11	19	7	-	10	5	-	25	14	F-102514
3M	21	A/B	20.05	19.29	11	19	7	-	11	5	-	25	14	F-102514
3M	22	A/B	21.01	20.25	11	19	7	-	11	6	-	25	14	F-102514
3M	24	A/B	22.92	22.16	11	19	7	-	14	6	-	28	18	F-102818
3M	25	A/B	23.87	23.11	11	19	7	-	14	6	-	28	18	F-102818
3M	26	A/B	24.83	24.07	11	19	7	-	15	6	-	28	18	F-102818
3M	28	A/B	26.74	25.98	11	19	7	-	17	6	-	31	20	F-103120
3M	30	A/B	28.65	27.89	11	19	7	-	19	6	-	33	22	F-103322
3M	32	A/B	30.56	29.8	11	19	7	-	20	6	-	33	22	F-103322
3M	34	A/B	32.47	31.71	11	19	7	-	22	8	-	38	26	F-103826
3M	36	A/B	34.38	33.62	11	19	7	-	24	8	-	38	26	F-103826
3M	38	A/B	36.29	35.53	11	19	7	-	26	8	-	43	28	F-104328
3M	40	A/B	38.2	37.44	11	19	7	-	28	8	-	44	32	F-104432
3M	46	A/B	43.93	43.16	11	19	7	-	32	10	-	51	36	F-105136
3M	48	A/B	45.84	45.07	11	19	7	-	32	10	-	51	36	F-105136
3M	60	A/B	57.3	56.53	11	19	7	-	36	12	-	65	30	F-156550

3M型齿形图:

表示方法:

▼ 3M型 同步带轮

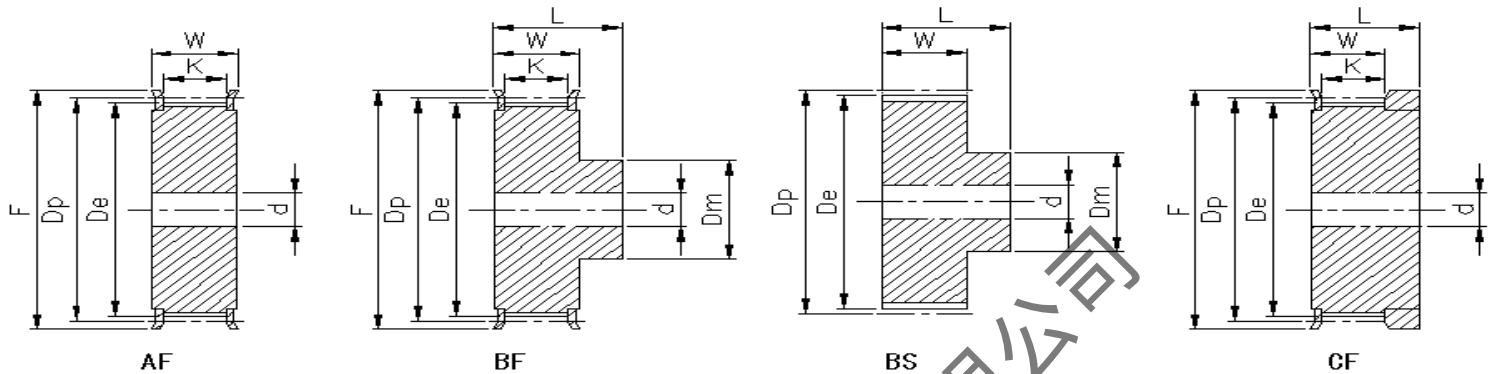
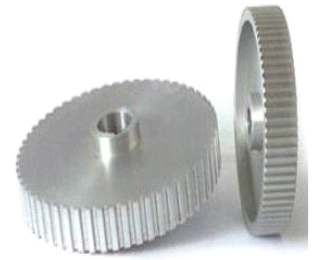
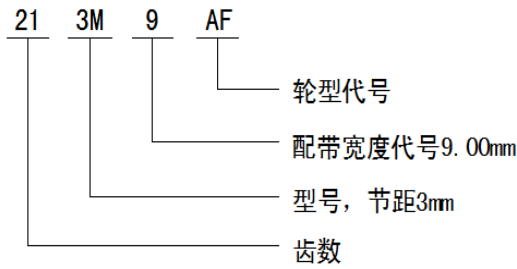
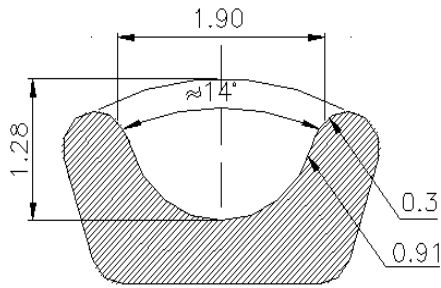

规格	齿数	形状	节径	外径	W	L	1K	X	轮毂直径	内孔	透孔外径	档边外径	档边内径	档边型号
3M	10	C/A	9.55	8.79	14	22	10	-	3	-	13	6	F-101306	
3M	11	C/A	10.5	9.74	14	22	10	-	3	-	14	7	F-101407	
3M	12	C/A	11.46	10.7	14	22	10	-	3	-	14	7	F-101407	
3M	14	C/A	13.37	12.61	14	22	10	-	4	-	13	9.5	F-101695	
3M	15	C/A	14.32	13.56	14	22	10	-	4	-	18	11	F-101811	
3M	16	C/A	15.28	14.52	14	22	10	-	10	4	-	18	11	F-101811
3M	18	C/A	17.19	16.43	14	22	10	-	10	5	-	23	12	F-102312
3M	19	C/A	18.14	17.38	14	22	10	-	10	5	-	25	13	F-102513
3M	20	C/A	19.1	18.34	14	22	10	-	10	5	-	25	14	F-102514
3M	21	A/B	20.05	19.29	14	22	10	-	11	5	-	25	14	F-102514
3M	22	A/B	21.01	20.25	14	22	10	-	11	6	-	25	14	F-102514
3M	24	A/B	22.92	22.16	14	22	10	-	14	6	-	28	18	F-102818
3M	25	A/B	23.87	23.11	14	22	10	-	14	6	-	28	18	F-102818
3M	26	A/B	24.83	24.07	14	22	10	-	15	6	-	28	18	F-102818
3M	28	A/B	26.74	25.98	14	22	10	-	17	6	-	31	20	F-103120
3M	30	A/B	28.65	27.89	14	22	10	-	19	6	-	33	22	F-103322
3M	32	A/B	30.56	29.8	14	22	10	-	20	6	-	33	22	F-103322
3M	34	A/B	32.47	31.71	14	22	10	-	22	8	-	38	26	F-103826
3M	36	A/B	34.38	33.62	14	22	10	-	24	8	-	38	26	F-103826
3M	38	A/B	36.29	35.53	14	22	10	-	26	8	-	43	28	F-104328
3M	40	A/B	38.2	37.44	14	22	10	-	28	8	-	44	32	F-104432
3M	46	A/B	43.93	43.16	14	22	10	-	32	10	-	51	36	F-105136
3M	48	A/B	45.84	45.07	14	22	10	-	32	10	-	51	36	F-105136
3M	60	A/B	57.3	56.53	14	22	10	-	36	12	-	65	30	F-156550

3M型齿形图:

表示方法:

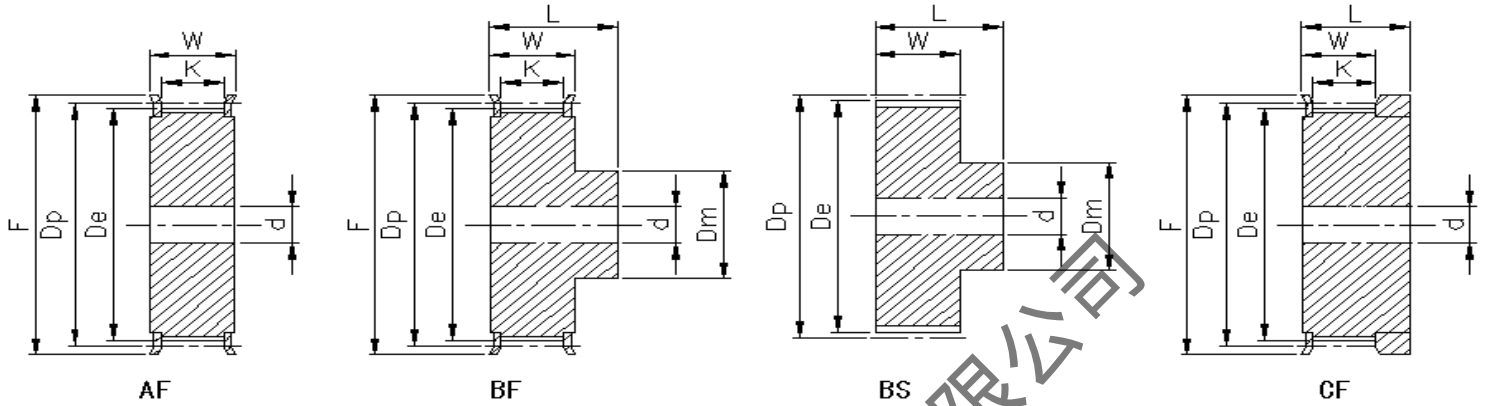
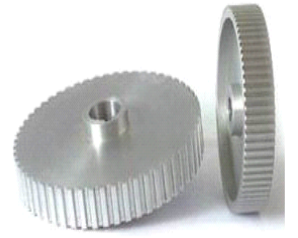
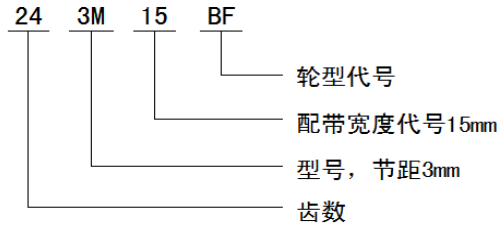
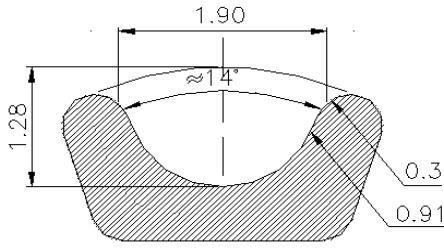

规格	齿数	形状	节径	外径	W	L	1K	X	轮毂直径	内孔	透孔外径	档边外径	档边内径	档边型号
3M	10	C/A	9.55	8.79	20	28	16	-	-	3	-	13	6	F-101306
3M	11	C/A	10.5	9.74	20	28	16	-	-	3	-	14	7	F-101407
3M	12	C/A	11.46	10.7	20	28	16	-	-	3	-	14	7	F-101407
3M	14	C/A	13.37	12.61	20	28	16	-	-	4	-	13	9.5	F-101695
3M	15	C/A	14.32	13.56	20	28	16	-	-	4	-	18	11	F-101811
3M	16	C/A	15.28	14.52	20	28	16	-	10	4	-	18	11	F-101811
3M	18	C/A	17.19	16.43	20	28	16	-	10	5	-	23	12	F-102312
3M	19	C/A	18.14	17.38	20	28	16	-	10	5	-	25	13	F-102513
3M	20	C/A	19.1	18.34	20	28	16	-	10	5	-	25	14	F-102514
3M	21	A/B	20.05	19.29	20	28	16	-	11	5	-	25	14	F-102514
3M	22	A/B	21.01	20.25	20	28	16	-	11	6	-	25	14	F-102514
3M	24	A/B	22.92	22.16	20	28	16	-	14	6	-	28	18	F-102818
3M	25	A/B	23.87	23.11	20	28	16	-	14	6	-	28	18	F-102818
3M	26	A/B	24.83	24.07	20	28	16	-	15	6	-	28	18	F-102818
3M	28	A/B	26.74	25.98	20	28	16	-	17	6	-	31	20	F-103120
3M	30	A/B	28.65	27.89	20	28	16	-	19	6	-	33	22	F-103322
3M	32	A/B	30.56	29.8	20	28	16	-	20	6	-	33	22	F-103322
3M	34	A/B	32.47	31.71	20	28	16	-	22	8	-	38	26	F-103826
3M	36	A/B	34.38	33.62	20	28	16	-	24	8	-	38	26	F-103826
3M	38	A/B	36.29	35.53	20	28	16	-	26	8	-	43	28	F-104328
3M	40	A/B	38.2	37.44	20	28	16	-	28	8	-	44	32	F-104432
3M	46	A/B	43.93	43.16	20	28	16	-	32	10	-	51	36	F-105136
3M	48	A/B	45.84	45.07	20	28	16	-	32	10	-	51	36	F-105136
3M	60	A/B	57.3	56.53	21	28	16	-	36	12	-	65	30	F-156550

5M型齿形图:

表示方法:

▼ 5M型 同步带轮

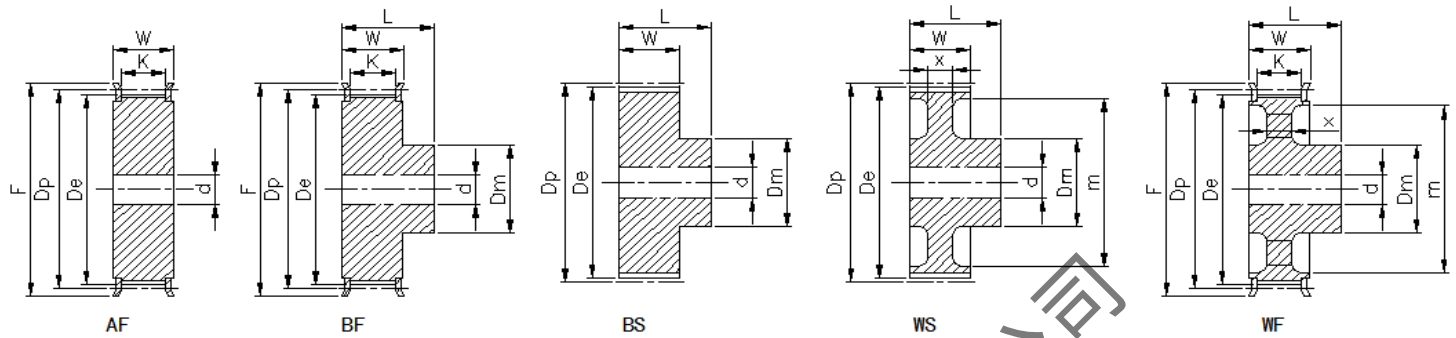
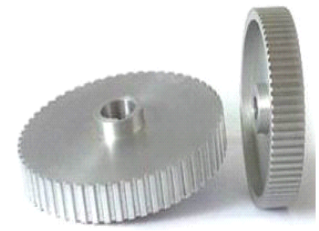
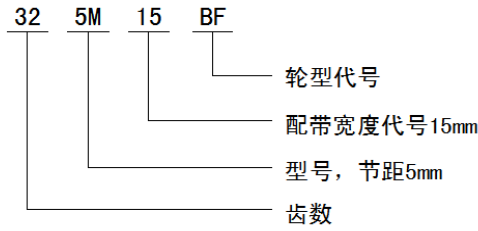
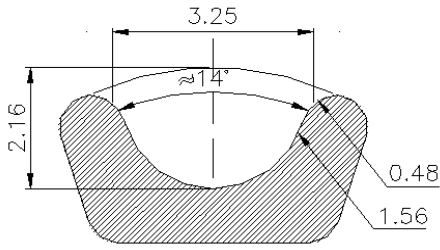

5M型标准皮带宽15mm

规格	齿数	形状	节径	外径	W	L	1K	X	轮毂直径	内孔	透孔外径	档边外径	档边内径	档边型号
5M	14	A/B	22.28	21.14	20	28	16	-	12	6	-	25	14	F-102514
5M	15	A/B	23.87	22.73	20	28	16	-	13	6	-	28	18	F-102818
5M	16	A/B	25.46	24.32	20	28	16	-	15	6	-	31	20	F-103120
5M	18	A/B	28.65	27.5	20	28	16	-	18	6	-	33	22	F-103322
5M	19	A/B	30.24	29.1	20	28	16	-	19	6	-	35	22	F-103522
5M	20	A/B	31.83	30.69	20	28	16	-	20	8	-	35	22	F-103522
5M	21	A/B	33.42	32.28	20	28	16	-	22	8	-	38	26	F-103826
5M	22	A/B	35.01	33.87	20	28	16	-	22	8	-	38	26	F-103826
5M	24	A/B	38.2	37.05	20	28	16	-	26	8	-	43	28	F-104328
5M	25	A/B	39.79	38.65	20	28	16	-	28	8	-	44	32	F-104432
5M	26	A/B	41.38	40.24	20	28	16	-	28	10	-	47	34	F-104734
5M	28	A/B	44.56	43.42	20	28	16	-	30	10	-	48	36	F-104836
5M	30	A/B	47.75	46.6	20	28	16	-	32	10	-	51	36	F-104836
5M	32	A/B	50.93	49.79	21	28	16	-	34	10	-	55	39	F-155539
5M	34	A/B	54.11	52.98	21	28	16	-	36	12	-	57	41	F-155741
5M	36	A/B	57.3	56.15	21	28	16	-	38	12	-	61	48	F-156148
5M	38	A/B	60.48	59.34	21	28	16	-	38	12	-	65	50	F-156550
5M	40	A/B	63.66	62.52	21	28	16	-	40	12	-	69	50	F-156950
5M	42	A/B	66.85	65.7	21	28	16	-	42	12	-	69	50	F-156950
5M	46	A/B	73.21	72.07	21	28	16	-	44	12	-	78	58	F-157858
5M	48	A/B	76.69	75.25	21	28	16	-	46	12	-	83	63	F-158363
5M	50	W	79.58	78.43	21	28	16	7	46	12	58	83	63	F-158363
5M	54	W	85.94	84.8	21	28	16	7	48	12	60	91	72	F-159172
5M	56	W	89.13	87.98	21	28	16	7	50	12	64	94	74	F-159474
5M	58	W	92.31	91.17	21	28	16	7	50	12	71	97	80	F-159780
5M	60	W	95.48	94.35	21	28	16	7	52	12	74	97	80	F-159780
5M	72	W	114.59	113.45	21	28	16	7	56	16	88	119	100	F-15119100

5M型齿形图:

表示方法:

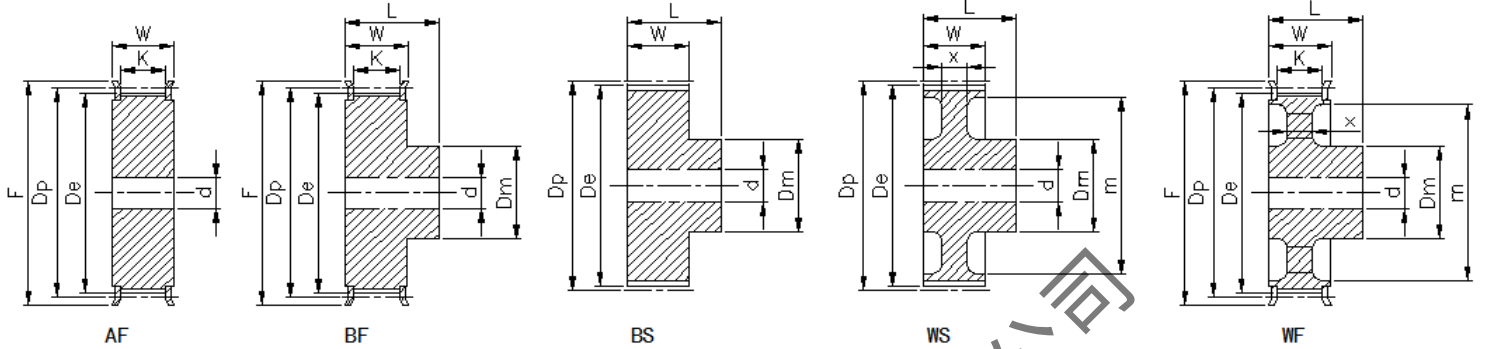
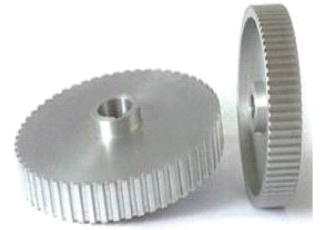
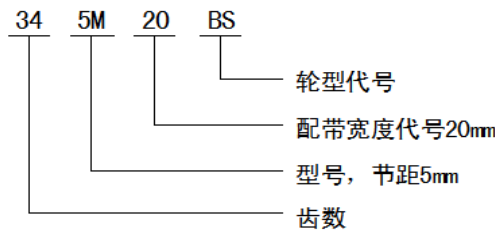
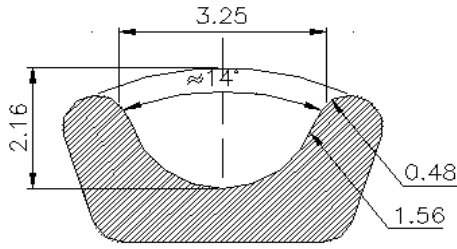

5M型标准皮带宽20mm

规格	齿数	形状	节径	外径	W	L	1K	X	轮毂直径	内孔	透孔外径	档边外径	档边内径	档边型号
5M	14	A/B	22.28	21.14	25	35	21	-	12	6	-	25	14	F-102514
5M	15	A/B	23.87	22.73	25	35	21	-	13	6	-	28	18	F-102818
5M	16	A/B	25.46	24.32	25	35	21	-	15	6	-	31	20	F-103120
5M	18	A/B	28.65	27.5	25	35	21	-	18	6	-	33	22	F-103322
5M	19	A/B	30.24	29.1	25	35	21	-	19	6	-	35	22	F-103522
5M	20	A/B	31.83	30.69	25	35	21	-	20	8	-	35	22	F-103522
5M	21	A/B	33.42	32.28	25	35	21	-	22	8	-	38	26	F-103826
5M	22	A/B	35.01	33.87	25	35	21	-	22	8	-	38	26	F-103826
5M	24	A/B	38.2	37.05	25	35	21	-	26	8	-	43	28	F-104328
5M	25	A/B	39.79	38.65	25	35	21	-	28	8	-	44	32	F-104432
5M	26	A/B	41.38	40.24	25	35	21	-	28	10	-	47	34	F-104734
5M	28	A/B	44.56	43.42	25	35	21	-	30	10	-	48	36	F-104836
5M	30	A/B	47.75	46.6	25	35	21	-	32	10	-	51	36	F-104836
5M	32	A/B	50.93	49.79	25	35	21	-	34	10	-	55	39	F-155539
5M	34	A/B	54.11	52.98	25	35	21	-	36	12	-	57	41	F-155741
5M	36	A/B	57.3	56.15	25	35	21	-	38	12	-	61	48	F-156148
5M	38	A/B	60.48	59.34	25	35	21	-	38	12	-	65	50	F-156550
5M	40	A/B	63.66	62.52	25	35	21	-	40	12	-	69	50	F-156950
5M	42	A/B	66.85	65.7	25	35	21	-	42	12	-	69	50	F-156950
5M	46	A/B	73.21	72.07	25	35	21	-	44	12	-	78	58	F-157858
5M	48	A/B	76.69	75.25	25	35	21	-	46	12	-	83	63	F-158363
5M	50	W	79.58	78.43	25	35	21	9	46	12	58	83	63	F-158363
5M	54	W	85.94	84.8	25	35	21	9	48	12	60	91	72	F-159172
5M	56	W	89.13	87.98	25	35	21	9	50	12	64	94	74	F-159474
5M	58	W	92.31	91.17	25	35	21	9	50	12	71	97	80	F-159780
5M	60	W	95.48	94.35	25	35	21	9	52	12	74	97	80	F-159780
5M	72	W	114.59	113.45	25	35	21	9	56	16	88	119	100	F-15119100

▼ 5M型 同步带轮

5M型齿形图:

表示方法:

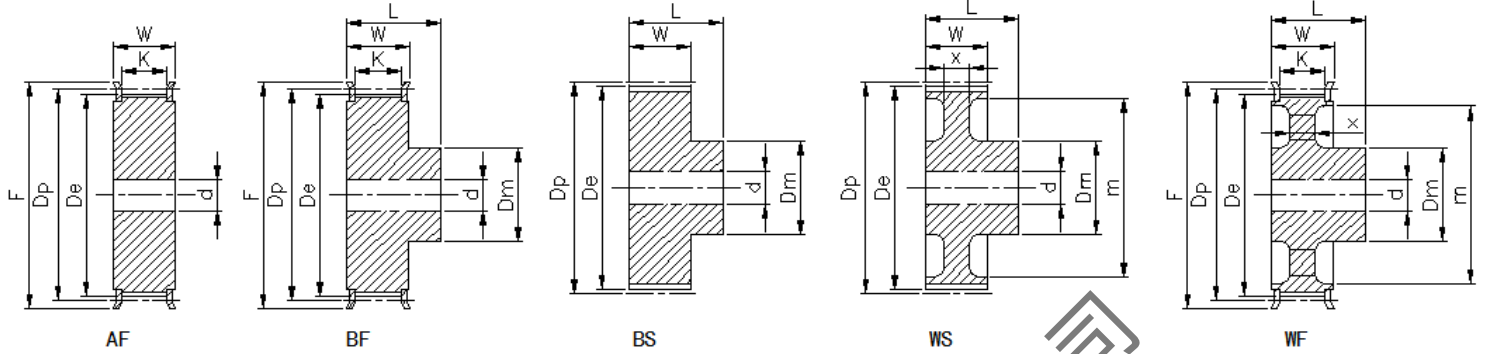
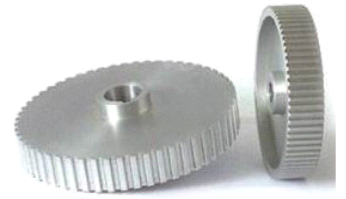
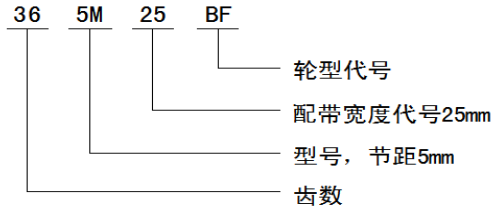
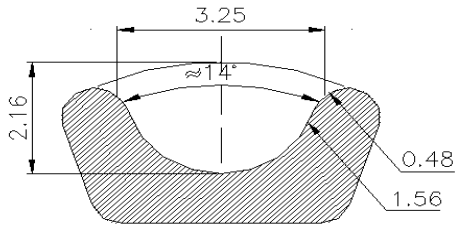

5M型标准皮带宽25mm

规格	齿数	形状	节径	外径	W	L	1K	X	轮毂直径	内孔	透孔外径	档边外径	档边内径	档边型号
5M	14	A/B	22.28	21.14	30	35	26	-	12	6	-	25	14	F-102514
5M	15	A/B	23.87	22.73	30	35	26	-	13	6	-	28	18	F-102818
5M	16	A/B	25.46	24.32	30	35	26	-	15	6	-	31	20	F-103120
5M	18	A/B	28.65	27.5	30	35	26	-	18	6	-	33	22	F-103322
5M	19	A/B	30.24	29.1	30	35	26	-	19	6	-	35	22	F-103522
5M	20	A/B	31.83	30.69	30	35	26	-	20	8	-	35	22	F-103522
5M	21	A/B	33.42	32.28	30	35	26	-	22	8	-	38	26	F-103826
5M	22	A/B	35.01	33.87	30	35	26	-	22	8	-	38	26	F-103826
5M	24	A/B	38.2	37.05	30	35	26	-	26	8	-	43	28	F-104328
5M	25	A/B	39.79	38.65	30	35	26	-	28	8	-	44	32	F-104432
5M	26	A/B	41.38	40.24	30	35	26	-	28	10	-	47	34	F-104734
5M	28	A/B	44.56	43.42	30	35	26	-	30	10	-	48	36	F-104836
5M	30	A/B	47.75	46.6	30	35	26	-	32	10	-	51	36	F-104836
5M	32	A/B	50.93	49.79	31	37	26	-	34	10	-	55	39	F-155539
5M	34	A/B	54.11	52.98	31	37	26	-	36	12	-	57	41	F-155741
5M	36	A/B	57.3	56.15	31	37	26	-	38	12	-	61	48	F-156148
5M	38	A/B	60.48	59.34	31	37	26	-	38	12	-	65	50	F-156550
5M	40	A/B	63.66	62.52	31	37	26	-	40	12	-	69	50	F-156950
5M	42	A/B	66.85	65.7	31	37	26	-	42	12	-	69	50	F-156950
5M	46	A/B	73.21	72.07	31	37	26	-	44	12	-	78	58	F-157858
5M	48	A/B	76.69	75.25	31	37	26	-	46	12	-	83	63	F-158363
5M	50	W	79.58	78.43	31	37	26	10	46	12	58	83	63	F-158363
5M	54	W	85.94	84.8	31	37	26	10	48	12	60	91	72	F-159172
5M	56	W	89.13	87.98	31	37	26	10	50	12	64	94	74	F-159474
5M	58	W	92.31	91.17	31	37	26	10	50	12	71	97	80	F-159780
5M	60	W	95.48	94.35	31	37	26	10	52	12	74	97	80	F-159780
5M	72	W	114.59	113.45	31	37	26	10	56	16	88	119	100	F-15119100

8M型齿形图:

表示方法:

▼ 8M型 同步带轮

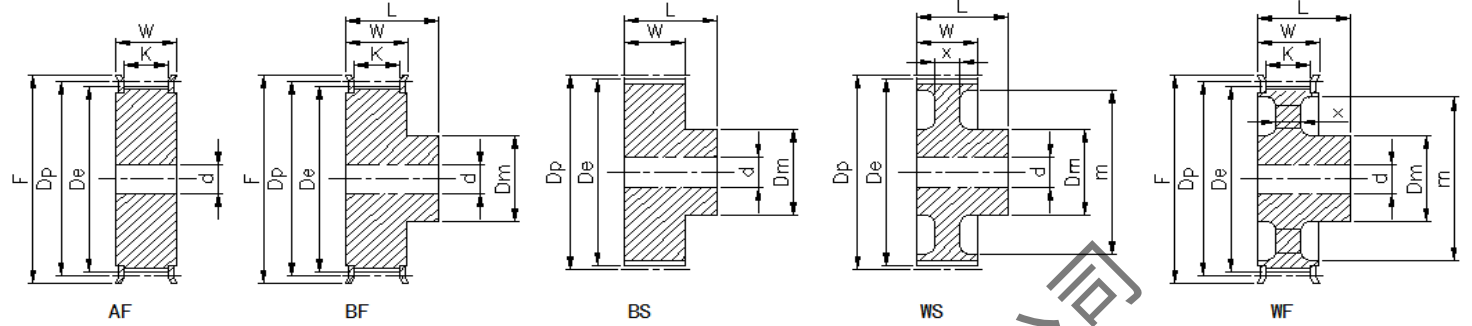
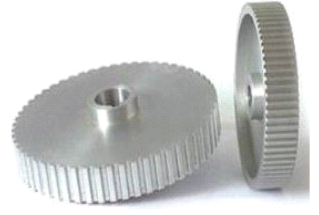
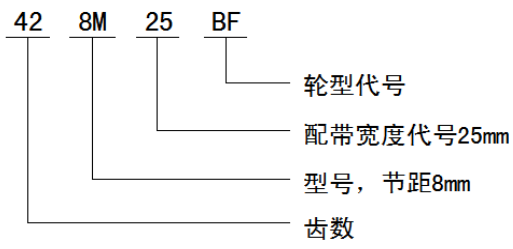
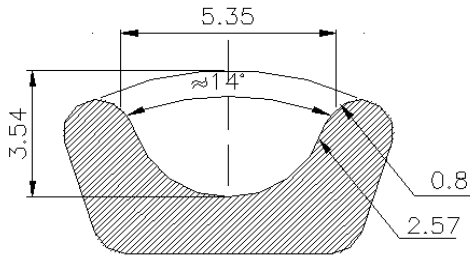

8M型标准皮带宽25mm

规格	齿数	形状	节径	外径	W	L	1K	X	轮毂直径	内孔	透孔外径	档边外径	档边内径	档边型号
8M	22	A/B	56.02	54.65	31	53	26	-	40	16	-	64	48	F-156448
8M	24	A/B	61.12	59.74	31	53	26	-	41	16	-	69	50	F-156950
8M	25	A/B	63.66	62.29	31	53	26	-	46	16	-	69	50	F-156950
8M	26	A/B	66.21	64.84	31	53	26	-	48	16	-	74	53	F-157453
8M	28	A/B	71.3	69.93	31	53	26	-	52	16	-	78	58	F-157858
8M	30	A/B	76.39	75.02	31	53	26	-	56	20	-	83	63	F-158363
8M	32	A/B	81.49	80.12	31	53	26	-	60	20	-	90	69	F-159069
8M	34	A/B	86.58	85.21	31	53	26	-	64	20	-	93	75	F-159375
8M	36	A/B	91.67	90.3	31	53	26	-	68	20	-	99	78	F-159978
8M	38	A/B	96.77	95.39	31	53	26	-	72	20	-	105	84	F-1510584
8M	40	A/B	101.86	100.49	31	53	26	-	74	20	-	112	90	F-1511290
8M	42	A/B	106.95	105.58	31	53	26	-	76	20	-	115	90	F-1511590
8M	44	A/B	112.05	110.67	31	53	26	-	78	20	-	121	99	F-1512199
8M	46	A/B	117.14	115.77	31	53	26	-	80	20	-	126	100	F-15126100
8M	48	A/B	122.23	120.86	31	53	26	-	80	20	-	131	111	F-15131111
8M	50	B/W	127.32	125.95	31	53	26	9	82	20	94	136	114	F-15136114
8M	52	B/W	132.42	131.05	31	53	26	9	84	20	99	141	118	F-15141118
8M	56	B/W	142.6	141.23	31	53	26	9	86	20	110	152	134	F-15152134
8M	58	B/W	147.7	146.32	31	53	26	9	88	30	115	156	135	F-15156135
8M	60	B/W	152.79	151.42	32	53	26	9	88	30	120	160	140	F-20160140
8M	62	B/W	157.88	156.51	32	53	26	9	90	30	125	166	145	F-20166145
8M	64	B/W	162.97	161.6	32	53	26	9	92	30	130	170	150	F-20170150
8M	67	B/W	170.61	169.24	32	53	26	9	94	30	138	179	158	F-20179158
8M	72	B/W	183.35	181.97	32	53	26	9	94	30	151	192	171	F-20192171
8M	80	B/W	203.72	202.35	32	53	26	9	98	30	171	212	191	F-20212191
8M	84	B/W	213.9	212.53	32	53	26	9	98	30	181	223	201	F-20223201
8M	90	B/W	229.18	227.81	32	53	26	9	100	30	196	238	216	F-20238216
8M	96	B/W	244.46	243.09	32	53	26	9	102	30	211	253	231	F-20253231
8M	112	B/W	285.21	283.83	32	53	26	9	108	40	252	294	272	F-20294272

8M型齿形图:

表示方法:

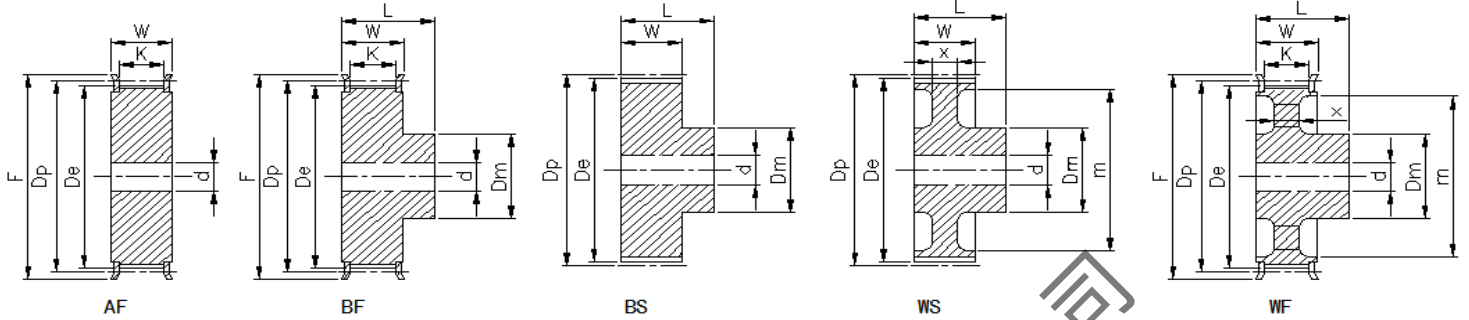
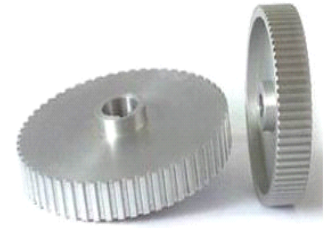
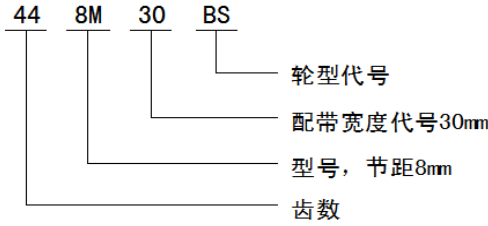
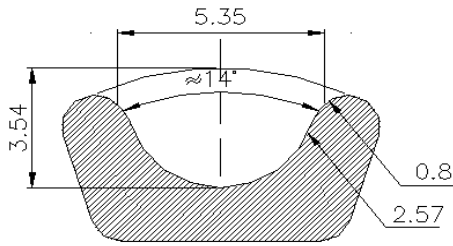

8M型标准皮带宽30mm

规格	齿数	形状	节径	外径	W	L	1K	X	轮毂直径	内孔	透孔外径	档边外径	档边内径	档边型号
8M	22	A/B	56.02	54.65	37	58	32	-	40	16	-	64	48	F-156448
8M	24	A/B	61.12	59.74	37	58	32	-	44	16	-	69	50	F-156950
8M	25	A/B	63.66	62.29	37	58	32	-	46	16	-	69	50	F-156950
8M	26	A/B	66.21	64.84	37	58	32	-	48	16	-	74	53	F-157453
8M	28	A/B	71.3	69.93	37	58	32	-	52	16	-	78	58	F-157858
8M	30	A/B	76.39	75.02	37	58	32	-	56	20	-	83	63	F-158363
8M	32	A/B	81.49	80.12	37	58	32	-	60	20	-	90	69	F-159069
8M	34	A/B	86.58	85.21	37	58	32	-	64	20	-	93	75	F-159375
8M	36	A/B	91.67	90.3	37	58	32	-	68	20	-	99	78	F-159978
8M	38	A/B	96.77	95.39	37	58	32	-	72	20	-	105	84	F-1510584
8M	40	A/B	101.86	100.49	37	58	32	-	74	20	-	112	90	F-1511290
8M	42	A/B	106.95	105.58	37	58	32	-	76	20	-	115	90	F-1511590
8M	44	A/B	112.05	110.67	38	58	32	-	78	20	-	121	99	F-1512199
8M	46	A/B	117.14	115.77	38	58	32	-	80	20	-	126	100	F-15126100
8M	48	A/B	122.23	120.86	38	58	32	-	80	20	-	131	111	F-15131111
8M	50	B/W	127.32	125.95	38	58	32	9	82	20	94	136	114	F-15136114
8M	52	B/W	132.42	131.05	38	58	32	9	84	20	99	141	118	F-15141118
8M	56	B/W	142.6	141.23	38	58	32	9	86	20	110	152	134	F-15152134
8M	58	B/W	147.7	146.32	38	58	32	9	88	30	115	156	135	F-15156135
8M	60	B/W	152.79	151.42	38	58	32	9	88	30	120	160	140	F-20160140
8M	62	B/W	157.88	156.51	38	58	32	9	90	30	125	166	145	F-20166145
8M	64	B/W	162.97	161.6	38	58	32	9	92	30	130	170	150	F-20170150
8M	67	B/W	170.61	169.24	38	58	32	9	94	30	138	179	158	F-20179158
8M	72	B/W	183.35	181.97	38	58	32	9	94	30	151	192	171	F-20192171
8M	80	B/W	203.72	202.35	38	58	32	9	98	30	171	212	191	F-20212191
8M	84	B/W	213.9	212.53	38	58	32	9	98	30	181	223	201	F-20223201
8M	90	B/W	229.18	227.81	38	58	32	9	100	30	196	238	216	F-20238216
8M	96	B/W	244.46	243.09	38	58	32	9	102	30	211	253	231	F-20253231
8M	112	B/W	285.21	283.83	38	58	32	9	108	40	252	294	272	F-20294272

8M型齿形图:

表示方法:

▼ 8M型 同步带轮

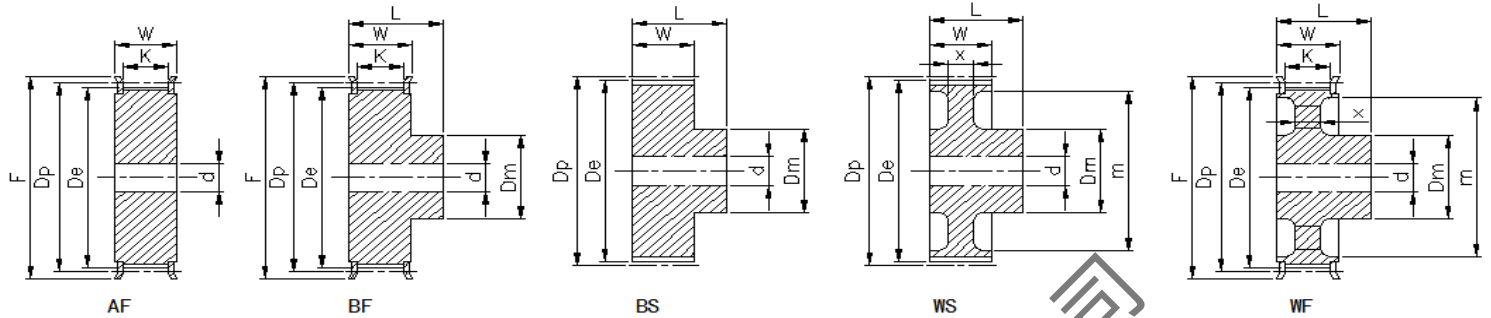
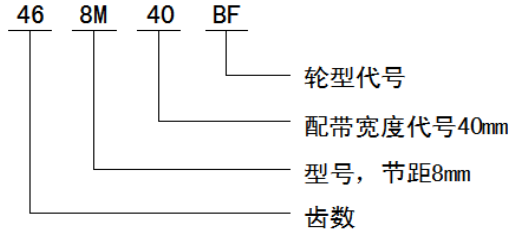
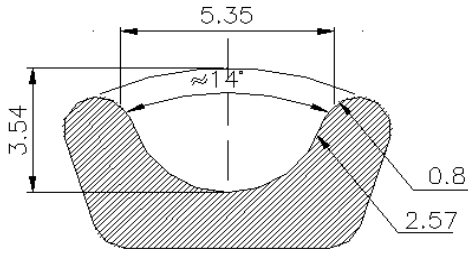

8M型标准皮带宽40mm

规格	齿数	形状	节径	外径	W	L	1K	X	轮毂直径	内孔	透孔外径	档边外径	档边内径	档边型号
8M	22	A/B	56.02	54.65	47	68	42	-	40	16	-	64	48	F-156448
8M	24	A/B	61.12	59.74	47	68	42	-	44	16	-	69	50	F-156950
8M	25	A/B	63.66	62.29	47	68	42	-	46	16	-	69	50	F-156950
8M	26	A/B	66.21	64.84	47	68	42	-	48	16	-	74	53	F-157453
8M	28	A/B	71.3	69.93	47	68	42	-	52	16	-	78	58	F-157858
8M	30	A/B	76.39	75.02	47	68	42	-	56	20	-	83	63	F-158363
8M	32	A/B	81.49	80.12	47	68	42	-	60	20	-	90	69	F-159069
8M	34	A/B	86.58	85.21	47	68	42	-	64	20	-	93	75	F-159375
8M	36	A/B	91.67	90.3	47	68	42	-	68	20	-	99	78	F-159978
8M	38	A/B	96.77	95.39	47	68	42	-	72	20	-	105	84	F-1510584
8M	40	A/B	101.86	100.49	47	68	42	-	74	20	-	112	90	F-1511290
8M	42	A/B	106.95	105.58	48	68	42	-	76	20	-	115	90	F-1511590
8M	44	A/B	112.05	110.67	48	68	42	-	78	20	-	121	99	F-1512199
8M	46	A/B	117.14	115.77	48	68	42	-	80	20	-	126	100	F-15126100
8M	48	A/B	122.23	120.86	48	68	42	-	80	20	-	131	111	F-15131111
8M	50	B/W	127.32	125.95	48	68	42	11	82	20	94	136	114	F-15136114
8M	52	B/W	132.42	131.04	48	68	42	11	84	20	99	141	118	F-15141118
8M	56	B/W	142.6	141.23	48	68	42	11	86	20	110	152	134	F-15152134
8M	58	B/W	147.7	146.32	48	68	42	11	88	30	115	156	135	F-15156135
8M	60	B/W	152.79	151.42	48	68	42	11	88	30	120	160	140	F-20160140
8M	62	B/W	157.88	156.51	48	68	42	11	90	30	125	166	145	F-20166145
8M	64	B/W	162.97	161.6	48	68	42	11	92	30	130	170	150	F-20170150
8M	67	B/W	170.61	169.24	48	68	42	11	94	30	138	179	158	F-20179158
8M	72	B/W	183.35	181.97	48	68	42	11	94	30	151	192	171	F-20192171
8M	80	B/W	203.72	202.35	48	68	42	11	98	30	171	212	191	F-20212191
8M	84	B/W	213.9	212.53	48	68	42	11	98	30	181	223	201	F-20223201
8M	90	B/W	229.18	227.81	48	68	42	11	100	30	196	238	216	F-20238216
8M	96	B/W	244.46	243.09	48	68	42	11	102	30	211	253	231	F-20253231
8M	112	B/W	285.21	283.83	48	68	42	11	108	40	252	294	272	F-20294272

8M型齿形图:

表示方法:

▼ 8M型 同步带轮

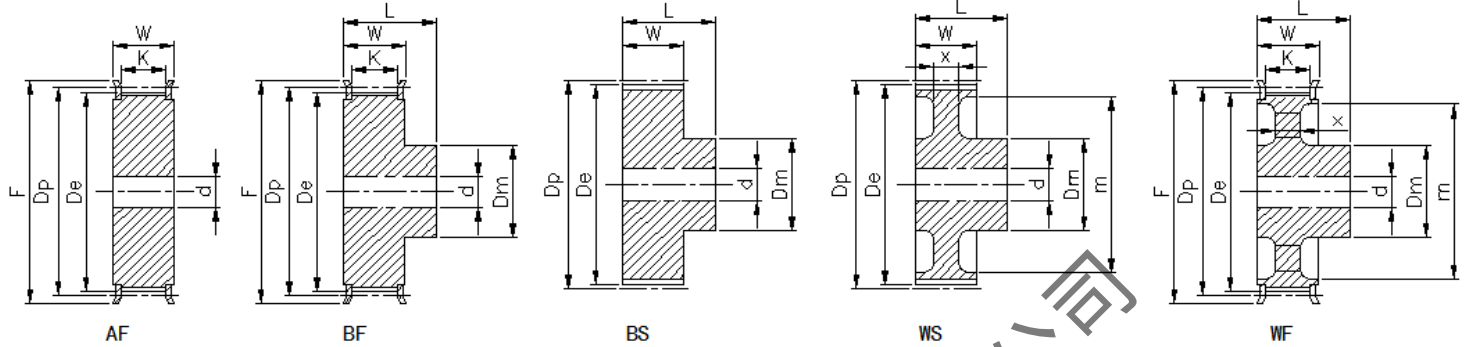
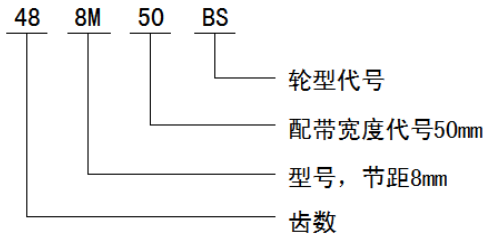
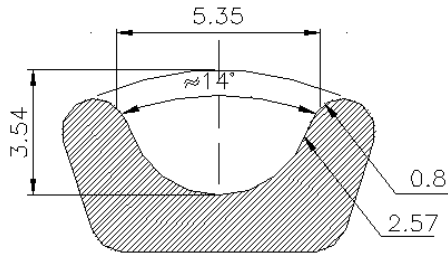

8M型同步带轮50mm

规格	齿数	形状	节径	外径	W	L	1K	X	轮毂直径	内孔	透孔外径	档边外径	档边内径	档边型号
8M	22	A/B	56.02	54.65	58	79	53	-	40	16	-	64	48	F-156448
8M	24	A/B	61.12	59.74	58	79	53	-	44	16	-	69	50	F-156950
8M	25	A/B	63.66	62.29	58	79	53	-	46	16	-	69	50	F-156950
8M	26	A/B	66.21	64.84	58	79	53	-	48	16	-	74	53	F-157453
8M	28	A/B	71.3	69.93	58	79	53	-	52	16	-	78	58	F-157858
8M	30	A/B	76.39	75.02	58	79	53	-	56	20	-	83	63	F-158363
8M	32	A/B	81.49	80.12	58	79	53	-	60	20	-	90	69	F-159069
8M	34	A/B	86.58	85.21	58	79	53	-	64	20	-	93	75	F-159375
8M	36	A/B	91.67	90.3	58	79	53	-	68	20	-	99	78	F-159978
8M	38	A/B	96.77	95.39	58	79	53	-	72	20	-	105	84	F-1510584
8M	40	A/B	101.86	100.49	58	79	53	-	74	20	-	112	90	F-1511290
8M	42	A/B	106.95	105.58	59	79	53	-	76	20	-	115	90	F-1511590
8M	44	A/B	112.05	110.67	59	79	53	-	78	20	-	121	99	F-1512199
8M	46	A/B	117.14	115.77	59	79	53	-	80	20	-	126	100	F-15126100
8M	48	A/B	122.23	120.86	59	79	53	-	80	20	-	131	111	F-15131111
8M	50	B/W	127.32	125.95	59	79	53	12	82	20	94	136	114	F-15136114
8M	52	B/W	132.42	131.4	59	79	53	12	84	20	99	141	118	F-15141118
8M	56	B/W	142.6	141.23	59	79	53	12	86	20	110	152	134	F-15152134
8M	58	B/W	147.7	146.32	59	79	53	12	88	30	115	156	135	F-15156135
8M	60	B/W	152.79	151.42	59	79	53	12	88	30	120	160	140	F-20160140
8M	62	B/W	157.88	156.51	59	79	53	12	90	30	125	166	145	F-20166145
8M	64	B/W	162.97	161.6	59	79	53	12	92	30	130	170	150	F-20170150
8M	67	B/W	170.61	169.24	59	79	53	12	94	30	138	179	158	F-20179158
8M	72	B/W	183.35	181.97	59	79	53	12	94	30	151	192	171	F-20192171
8M	80	B/W	203.72	202.35	59	79	53	12	98	30	171	212	191	F-20212191
8M	84	B/W	213.9	212.53	59	79	53	12	98	30	181	223	201	F-20223201
8M	90	B/W	229.18	227.81	59	79	53	12	100	30	196	238	216	F-20238216
8M	96	B/W	244.46	243.09	59	79	53	12	102	30	211	253	231	F-20253231
8M	112	B/W	285.21	283.83	59	79	53	12	108	40	252	294	272	F-20294272

8M型齿形图:

表示方法:

▼ 8M型 同步带轮

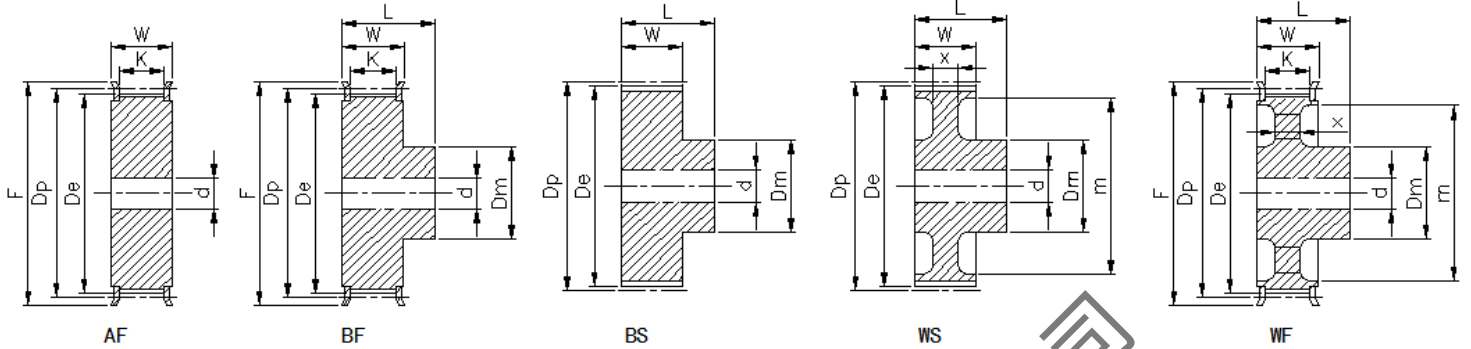
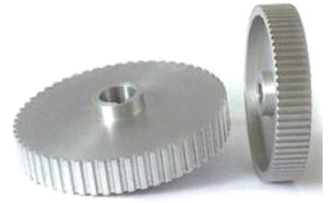
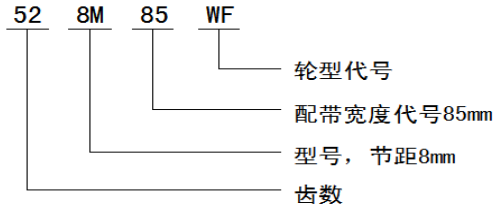
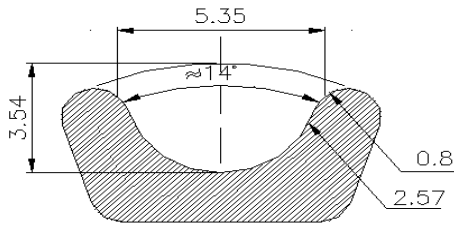

8M型标准皮带宽85mm

规格	齿数	形状	节径	外径	W	L	1K	X	轮毂直径	内孔	透孔外径	档边外径	档边内径	档边型号
8M	22	A/B	56.02	54.65	93	99	87	-	40	16	-	64	48	F-156448
8M	24	A/B	61.12	59.74	93	99	87	-	44	16	-	69	50	F-156950
8M	25	A/B	63.66	62.29	93	99	87	-	46	16	-	69	50	F-156950
8M	26	A/B	66.21	64.84	93	99	87	-	48	16	-	74	53	F-157453
8M	28	A/B	71.3	69.93	93	99	87	-	52	16	-	78	58	F-157858
8M	30	A/B	76.39	75.02	93	99	87	-	56	20	-	83	63	F-158363
8M	32	A/B	81.49	80.12	93	99	87	-	60	20	-	90	69	F-159069
8M	34	A/B	86.58	85.21	93	99	87	-	64	20	-	93	75	F-159375
8M	36	A/B	91.67	90.3	93	99	87	-	68	20	-	99	78	F-159978
8M	38	A/B	96.77	95.39	93	99	87	-	72	20	-	105	84	F-1510584
8M	40	A/B	101.86	100.49	93	99	87	-	74	20	-	112	90	F-1511290
8M	42	A/B	106.95	105.58	94	99	87	-	76	20	-	115	90	F-1511590
8M	44	A/B	112.05	110.67	94	99	87	-	78	20	-	121	99	F-1512199
8M	46	A/B	117.14	115.77	94	99	87	-	80	20	-	126	100	F-15126100
8M	48	A/B	122.23	120.86	94	99	87	-	80	20	-	131	111	F-15131111
8M	50	B/W	127.32	125.95	95	99	87	26	82	20	94	136	114	F-15136114
8M	52	B/W	132.42	131.4	95	99	87	26	84	20	99	141	118	F-15141118
8M	56	B/W	142.6	141.23	95	99	87	26	86	20	110	152	134	F-15152134
8M	58	B/W	147.7	146.32	95	99	87	26	88	30	115	156	135	F-15156135
8M	60	B/W	152.79	151.42	95	99	87	26	88	30	120	160	140	F-20160140
8M	62	B/W	157.88	156.51	95	99	87	26	90	30	125	166	145	F-20166145
8M	64	B/W	162.97	161.6	95	99	87	26	92	30	130	170	150	F-20170150
8M	67	B/W	170.61	169.24	95	99	87	26	94	30	138	179	158	F-20179158
8M	72	B/W	183.35	181.97	95	99	87	26	94	30	151	192	171	F-20192171
8M	80	B/W	203.72	202.35	95	99	87	26	98	30	171	212	191	F-20212191
8M	84	B/W	213.9	212.53	95	99	87	26	98	30	181	223	201	F-20223201
8M	90	B/W	229.18	227.81	95	99	87	26	100	30	196	238	216	F-20238216
8M	96	B/W	244.46	243.09	95	99	87	26	102	30	211	253	231	F-20253231
8M	112	B/W	285.21	283.83	95	99	87	26	108	40	252	294	272	F-20294272

14M型齿形图:

表示方法:

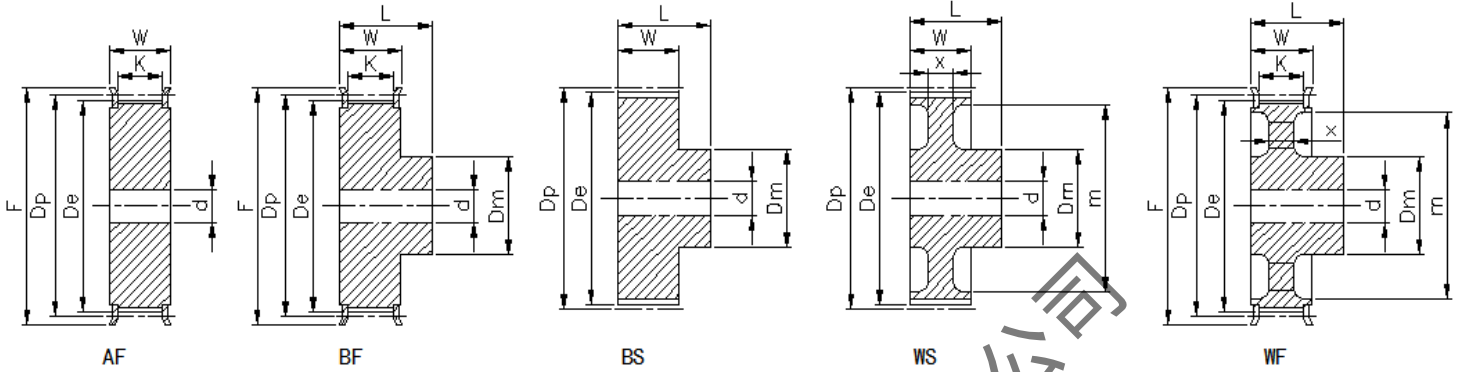
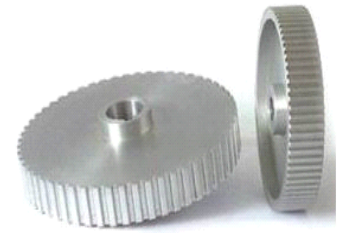
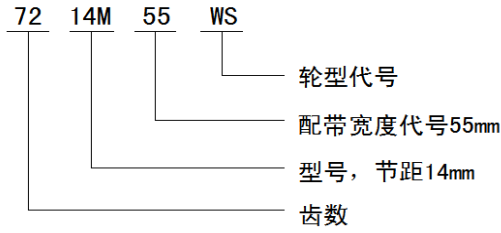
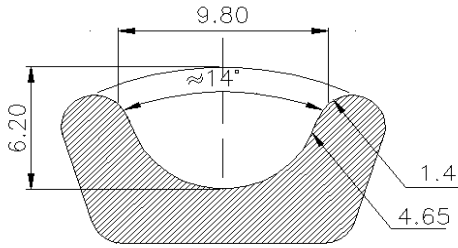

14M型标准皮带宽55mm

规格	齿数	形状	节径	外径	W	L	1K	X	轮毂直径	内孔	透孔外径	档边外径	档边内径	档边型号
28-14M	28	A/B	124.78	121.98	66	91	60	-	92	25	-	137	106	F-25137106
29-14M	29	A/B	129.23	126.44	66	91	60	-	94	25	-	141	111	F-25141111
30-14M	30	A/B	133.69	130.9	66	91	60	-	96	25	-	146	115	F-25146115
32-14M	32	A/B	142.6	139.81	66	91	60	-	100	25	-	155	123	F-25155123
34-14M	34	A/B	151.52	148.72	66	91	60	-	104	25	-	164	132	F-25164132
36-14M	36	A/B	160.43	157.63	66	91	60	-	108	30	-	173	140	F-25173140
38-14M	38	A/B	169.34	166.55	66	91	60	-	112	30	-	182	149	F-25182149
40-14M	40	B/W	178.25	175.46	66	91	60	16	114	30	136	190	158	F-25190158
42-14M	42	B/W	187.17	184.37	66	91	60	16	116	30	145	200	167	F-25200167
44-14M	44	B/W	196.08	193.28	66	91	60	16	118	30	154	208	176	F-25208176
46-14M	46	B/W	204.99	202.2	66	91	60	16	118	30	163	217	185	F-25217185
48-14M	48	B/W	213.9	211.11	66	91	60	16	120	30	172	226	194	F-25116194
56-14M	56	B/W	249.55	246.76	66	91	60	16	124	40	207	262	229	F-25262229
60-14M	60	B/W	267.38	364.59	66	91	60	16	128	40	225	280	247	F-25280247
64-14M	64	B/W	285.21	282.41	66	91	60	16	130	40	243	297	265	F-25297265
72-14M	72	B/W	320.86	318.06	66	91	60	16	134	50	279	333	301	F-25333301
80-14M	80	B/W	356.51	353.71	66	91	60	16	138	50	314	369	336	F-25369336
84-14M	84	B/W	374.33	371.54	66	91	60	16	140	50	332	387	354	F-25387354
90-14M	90	B/W	401.07	398.28	66	91	60	16	142	50	359	413	381	F-25413381
96-14M	96	B/W	427.81	425.01	66	91	60	16	146	50	385	440	407	F-25440407
112-14M	112	B/W	499.11	496.32	66	91	60	16	154	50	457	-	-	-
144-14M	144	B/W	641.71	638.92	66	91	60	16	170	60	600	-	-	-

14M型齿形图:

表示方法:

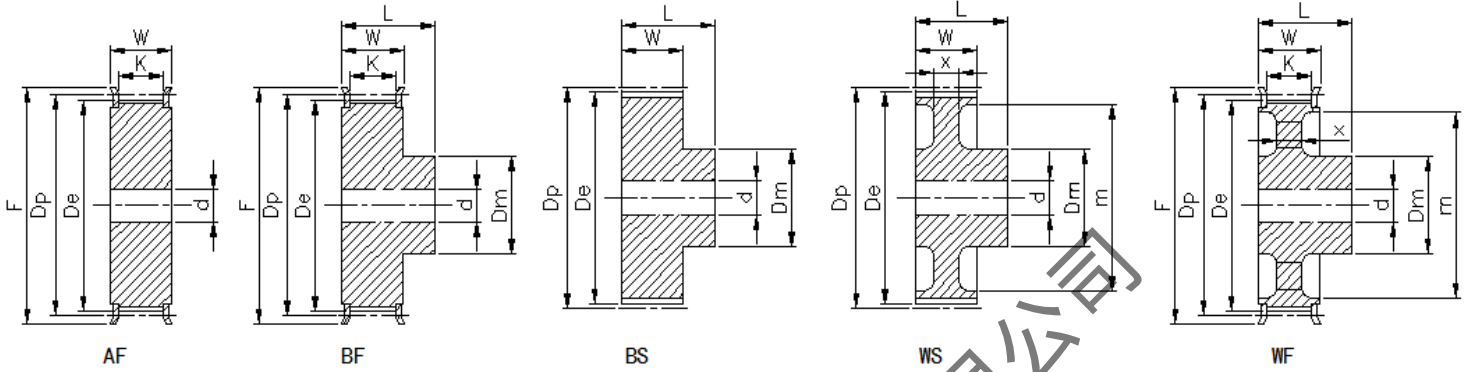
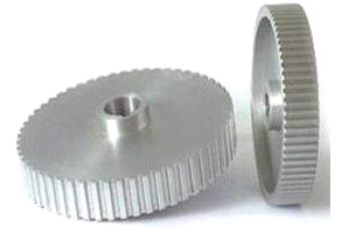
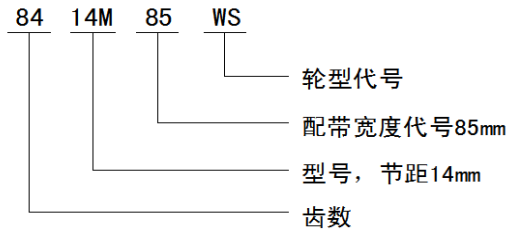
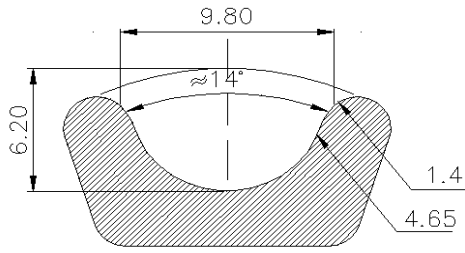

14M型标准皮带宽85mm

规格	齿数	形状	节径	外径	W	L	1K	X	轮毂直径	内孔	透孔外径	档边外径	档边内径	档边型号
28-14M	28	A/B	124.78	121.98	97	122	90	-	92	25	-	137	106	F-25137106
29-14M	29	A/B	129.23	126.44	97	122	90	-	94	25	-	141	111	F-25141111
30-14M	30	A/B	133.69	130.9	97	122	90	-	96	25	-	146	115	F-25146115
32-14M	32	A/B	142.6	139.81	97	122	90	-	100	25	-	155	123	F-25155123
34-14M	34	A/B	151.52	148.72	97	122	90	-	104	25	-	164	132	F-25164132
36-14M	36	A/B	160.43	157.63	97	122	90	-	108	30	-	173	140	F-25173140
38-14M	38	A/B	169.34	166.55	97	122	90	-	112	30	-	182	149	F-25182149
40-14M	40	B/W	178.25	175.46	97	122	90	19	114	30	136	190	158	F-25190158
42-14M	42	B/W	187.17	184.37	97	122	90	19	116	30	145	200	167	F-25200167
44-14M	44	B/W	196.08	193.28	97	122	90	19	118	30	154	208	176	F-25208176
46-14M	46	B/W	204.99	202.2	97	122	90	19	118	30	163	217	185	F-25217185
48-14M	48	B/W	213.9	211.11	97	122	90	19	120	30	172	226	194	F-25116194
56-14M	56	B/W	249.55	246.76	97	122	90	19	124	40	207	262	229	F-25262229
60-14M	60	B/W	267.38	364.59	97	122	90	19	128	40	225	280	247	F-25280247
64-14M	64	B/W	285.21	282.41	97	122	90	19	130	40	243	297	265	F-25297265
72-14M	72	B/W	320.86	318.06	97	122	90	19	134	50	279	333	301	F-25333301
80-14M	80	B/W	356.51	353.71	97	122	90	19	138	50	314	369	336	F-25369336
84-14M	84	B/W	374.33	371.54	97	122	90	19	140	50	332	387	354	F-25387354
90-14M	90	B/W	401.07	398.28	97	122	90	19	142	50	359	413	381	F-25413381
96-14M	96	B/W	427.81	425.01	97	122	90	19	146	50	385	440	407	F-25440407
112-14M	112	B/W	499.11	496.32	97	122	90	19	154	50	457	-	-	-
144-14M	144	B/W	641.71	638.92	97	122	90	19	170	60	600	-	-	-

14M型齿形图:

表示方法:

▼ 14M型 同步带轮

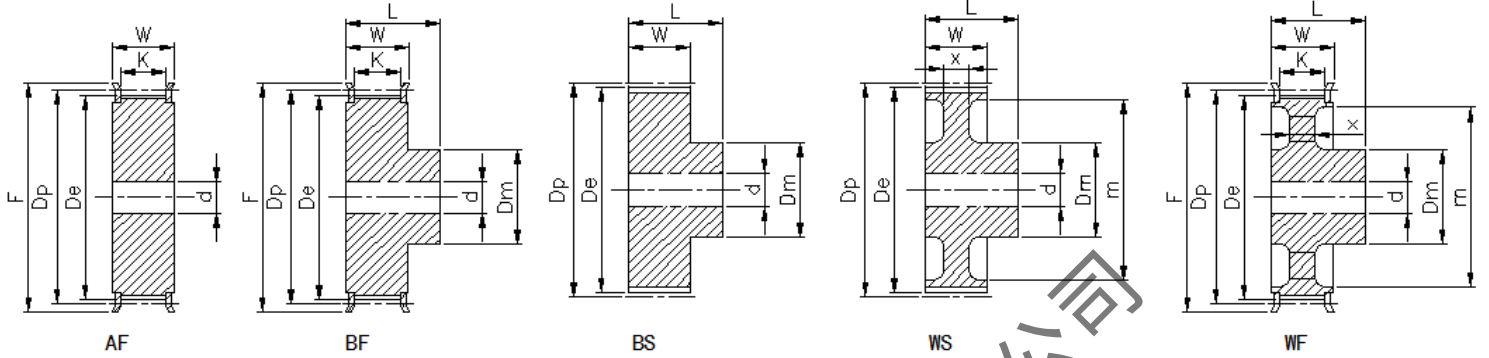
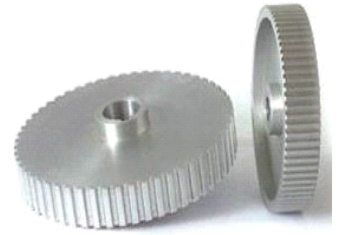
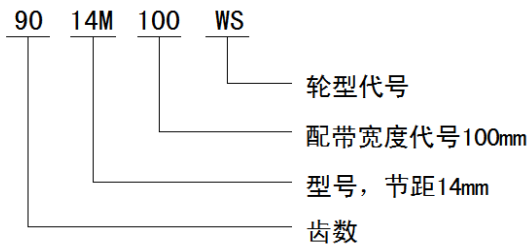
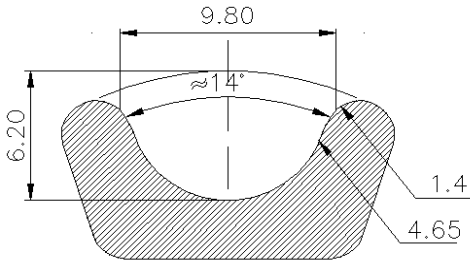

14M型标准皮带宽100mm

规格	齿数	形状	节径	外径	W	L	1K	X	轮毂直径	齿孔	透孔外径	档边外径	档边内径	档边型号
28-14M	28	A/B	124.78	121.98	112	137	105	-	92	25	-	137	106	F-25137106
29-14M	29	A/B	129.23	126.44	112	137	105	-	94	25	-	141	111	F-25141111
30-14M	30	A/B	133.69	130.9	112	137	105	-	96	25	-	146	115	F-25146115
32-14M	32	A/B	142.6	139.81	112	137	105	-	100	25	-	155	123	F-25155123
34-14M	34	A/B	151.52	148.72	112	137	105	-	104	25	-	164	132	F-25164132
36-14M	36	A/B	160.43	157.63	112	137	105	-	108	30	-	173	140	F-25173140
38-14M	38	A/B	169.34	166.55	112	137	105	-	112	30	-	182	149	F-25182149
40-14M	40	B/W	178.25	175.46	112	137	105	22	114	30	136	190	158	F-25190158
42-14M	42	B/W	187.17	184.37	112	137	105	22	116	30	145	200	167	F-25200167
44-14M	44	B/W	196.08	193.28	112	137	105	22	118	30	154	208	176	F-25208176
46-14M	46	B/W	204.99	202.2	112	137	105	22	118	30	163	217	185	F-25217185
48-14M	48	B/W	213.9	211.11	112	137	105	22	120	30	172	226	194	F-25116194
56-14M	56	B/W	249.55	246.76	112	137	105	22	124	40	207	262	229	F-25262229
60-14M	60	B/W	267.38	364.59	112	137	105	22	128	40	225	280	247	F-25280247
64-14M	64	B/W	285.21	282.41	112	137	105	22	130	40	243	297	265	F-25297265
72-14M	72	B/W	320.86	318.06	112	137	105	22	134	50	279	333	301	F-25333301
80-14M	80	B/W	356.51	353.71	112	137	105	22	138	50	314	369	336	F-25369336
84-14M	84	B/W	374.33	371.54	112	137	105	22	140	50	332	387	354	F-25387354
90-14M	90	B/W	401.07	398.28	112	137	105	22	142	50	359	413	381	F-25413381
96-14M	96	B/W	427.81	425.01	112	137	105	22	146	50	385	440	407	F-25440407
112-14M	112	B/W	499.11	496.32	112	137	105	22	154	50	457	-	-	-
144-14M	144	B/W	641.71	638.92	112	137	105	22	170	60	600	-	-	-

▼ 14M型 同步带轮

14M型齿形图:

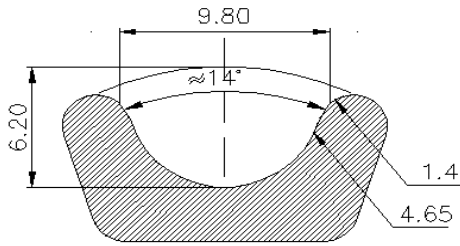

表示方法:

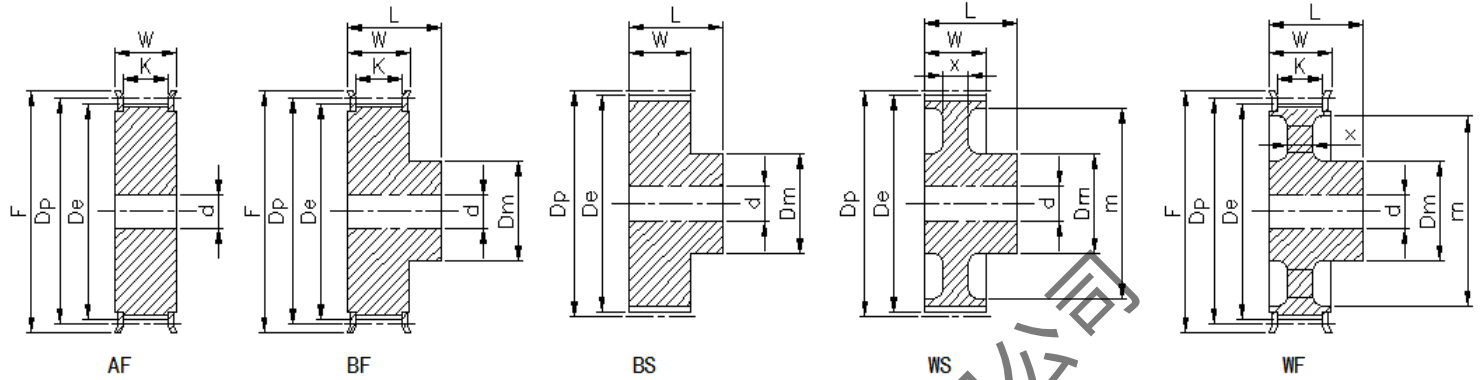
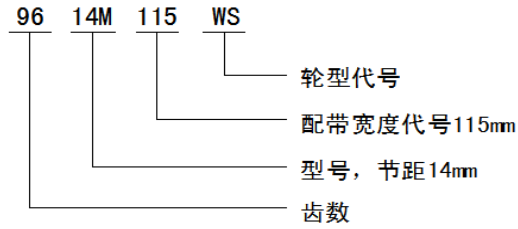

14M型标准皮带宽115mm

规格	齿数	形状	节径	外径	W	L	1K	X	轮毂直径	内孔	透孔外径	档边外径	档边内径	档边型号
28-14M	28	A/B	124.78	121.98	128	153	120	-	92	25	-	137	106	F-25137106
29-14M	29	A/B	129.23	126.44	128	153	120	-	94	25	-	141	111	F-25141111
30-14M	30	A/B	133.69	130.9	128	153	120	-	96	25	-	146	115	F-25146115
32-14M	32	A/B	142.6	139.81	128	153	120	-	100	25	-	155	123	F-25155123
34-14M	34	A/B	151.52	148.72	128	153	120	-	104	25	-	164	132	F-25164132
36-14M	36	A/B	160.43	157.63	128	153	120	-	108	30	-	173	140	F-25173140
38-14M	38	A/B	169.34	166.55	128	153	120	-	112	30	-	182	149	F-25182149
40-14M	40	B/W	178.25	175.46	128	153	120	26	114	30	136	190	158	F-25190158
42-14M	42	B/W	187.17	184.37	128	153	120	26	116	30	145	200	167	F-25200167
44-14M	44	B/W	196.08	193.28	128	153	120	26	118	30	154	208	176	F-25208176
46-14M	46	B/W	204.99	202.2	128	153	120	26	118	30	163	217	185	F-25217185
48-14M	48	B/W	213.9	211.11	128	153	120	26	120	30	172	226	194	F-25116194
56-14M	56	B/W	249.55	246.76	128	153	120	26	124	40	207	262	229	F-25262229
60-14M	60	B/W	267.38	364.59	128	153	120	26	128	40	225	280	247	F-25280247
64-14M	64	B/W	285.21	282.41	128	153	120	26	130	40	243	297	265	F-25297265
72-14M	72	B/W	320.86	318.06	128	153	120	26	134	50	279	333	301	F-25333301
80-14M	80	B/W	356.51	353.71	128	153	120	26	138	50	314	369	336	F-25369336
84-14M	84	B/W	374.33	371.54	128	153	120	26	140	50	332	387	354	F-25387354
90-14M	90	B/W	401.07	398.28	128	153	120	26	142	50	359	413	381	F-25413381
96-14M	96	B/W	427.81	425.01	128	153	120	26	146	50	385	440	407	F-25440407
112-14M	112	B/W	499.11	496.32	128	153	120	26	154	50	457	-	-	-
144-14M	144	B/W	641.71	638.92	128	153	120	26	170	60	600	-	-	-

20M型齿形图:

表示方法:

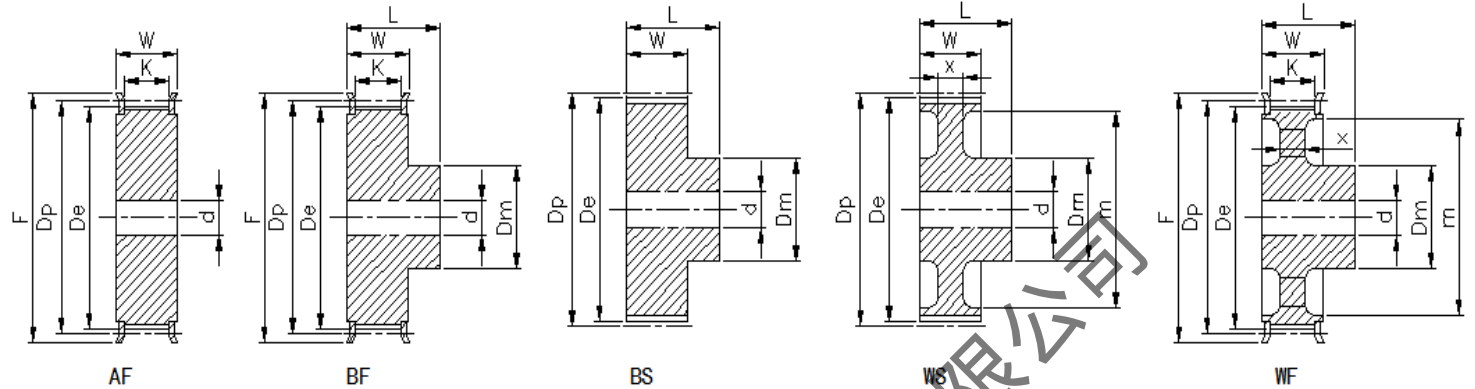
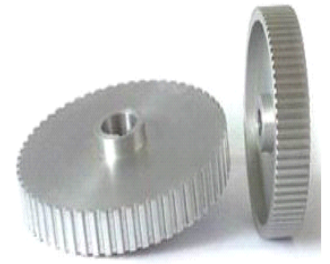
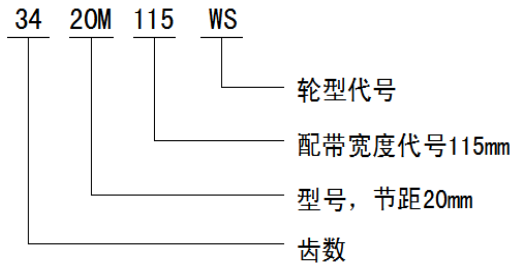
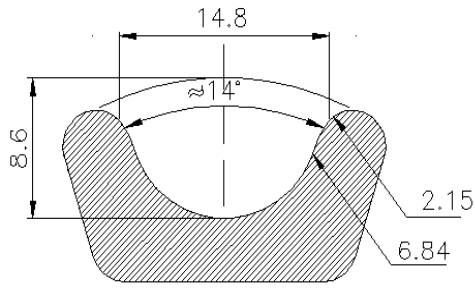

20M型标准皮带宽115mm

规格	齿数	形状	节径	外径	W	L	1K	X	轮毂直径	内孔	透孔外径	档边外径	档边内径	档边型号
34-20M	34	B/W	216.45	212.13	135	168	125	-	165	32	-	240	165	F-40240165
36-20M	36	B/W	229.18	224.87	135	168	125	-	178	32	-	250	178	F-40250178
38-20M	38	B/W	241.92	237.6	135	168	125	-	181	32	-	265	190	F-40265190
40-20M	40	B/W	254.56	250.33	135	168	125	-	203	32	-	275	203	F-40275203
44-20M	44	B/W	280.11	275.79	135	168	125	-	210	32	-	300	228	F-40300228
48-20M	48	B/W	305.88	301.26	135	168	125	-	228	32	-	325	254	F-40325254
52-20M	52	B/W	331.04	326.72	135	168	125	-	228	32	-	350	279	F-40350279
56-20M	56	B/W	356.51	352.19	135	168	125	-	228	32	-	375	305	F-40375305
60-20M	60	W	381.97	377.65	135	168	125	30	228	38	318	405	330	F-40405330
64-20M	64	W	407.44	403.12	135	168	125	30	228	38	343	430	356	F-40430356
68-20M	68	W	432.9	428.58	135	168	125	30	228	38	366	455	382	F-40455382
72-20M	72	W	458.37	454.05	135	168	125	30	228	38	392	480	407	F-40480407
80-20M	80	W	509.3	504.98	135	168	125	30	280	38	445	530	457	F-40530457
90-20M	90	W	572.96	568.64	135	168	125	30	280	38	508	595	521	F-40595521

20M型标准皮带宽170mm

规格	齿数	形状	节径	外径	W	L	1K	X	轮毂直径	内孔	透孔外径	档边外径	档边内径	档边型号
34-20M	34	B/W	216.45	212.13	192	223	180	-	165	32	-	240	165	F-40240165
36-20M	36	B/W	229.18	224.87	192	223	180	-	178	32	-	250	178	F-40250178
38-20M	38	B/W	241.92	237.6	192	223	180	-	181	32	-	265	190	F-40265190
40-20M	40	B/W	254.56	250.33	192	223	180	-	203	32	-	275	203	F-40275203
44-20M	44	B/W	280.11	275.79	192	223	180	-	210	32	-	300	228	F-40300228
48-20M	48	B/W	305.88	301.26	192	223	180	-	228	32	-	325	254	F-40325254
52-20M	52	B/W	331.04	326.72	192	223	180	-	228	32	-	350	279	F-40350279
56-20M	56	B/W	356.51	352.19	192	223	180	-	228	32	-	375	305	F-40375305
60-20M	60	W	381.97	377.65	192	223	180	30	228	38	318	405	330	F-40405330
64-20M	64	W	407.44	403.12	192	223	180	30	228	38	343	430	356	F-40430356
68-20M	68	W	432.9	428.58	192	223	180	30	228	38	366	455	382	F-40455382
72-20M	72	W	458.37	454.05	192	223	180	30	228	38	392	480	407	F-40480407
80-20M	80	W	509.3	504.98	192	223	180	30	280	38	445	530	457	F-40530457
90-20M	90	W	572.96	568.64	192	223	180	30	280	38	508	595	521	F-40595521

20M型齿形图:

表示方法:

▼ 20M型 同步带轮

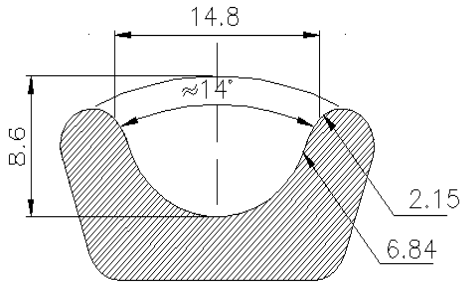

38 20M 230 WS
 轮型代号
 配带宽度代号115mm
 型号, 节距20mm
 齿数

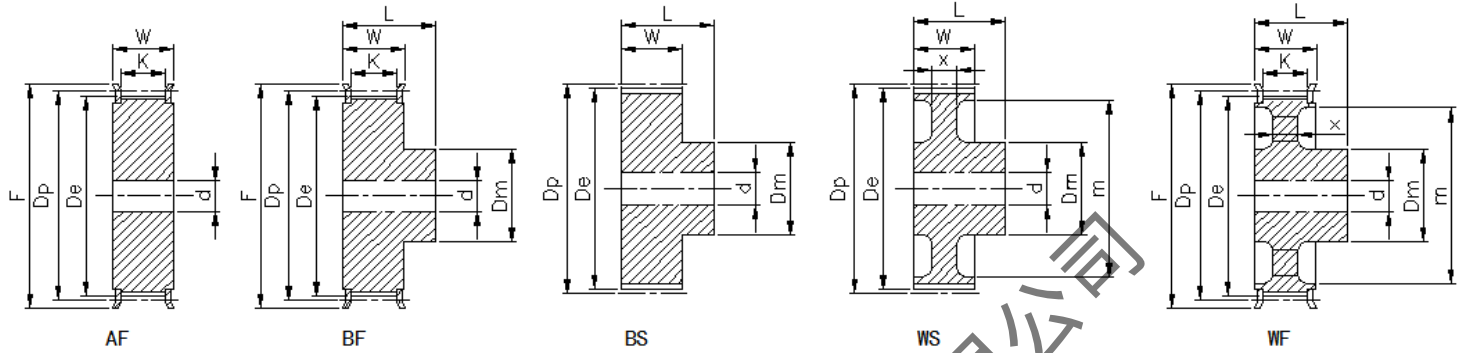
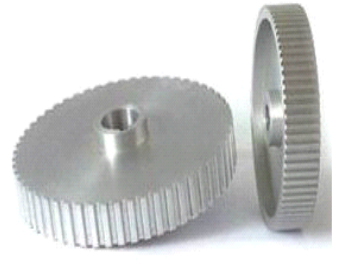

20M型标准皮带宽230mm

规格	齿数	形状	节径	外径	W	L	1K	X	轮毂直径	内孔	透孔外径	档边外径	档边内径	档边型号
34-20M	34	B/W	216.45	212.13	250	283	240	-	165	32	-	240	165	F-40240165
36-20M	36	B/W	229.18	224.87	250	283	240	-	178	32	-	250	178	F-40250178
38-20M	38	B/W	241.92	237.6	250	283	240	-	181	32	-	265	190	F-40265190
40-20M	40	B/W	254.56	250.33	250	283	240	-	203	32	-	275	203	F-40275203
44-20M	44	B/W	280.11	275.79	250	283	240	-	210	32	-	300	228	F-40300228
48-20M	48	B/W	305.88	301.26	250	283	240	-	228	32	-	325	254	F-40325254
52-20M	52	B/W	331.04	326.72	250	283	240	-	228	32	-	350	279	F-40350279
56-20M	56	B/W	356.51	352.19	250	288	240	-	228	32	-	375	305	F-40375305
60-20M	60	W	381.97	377.65	250	283	240	40	228	38	318	405	330	F-40405330
64-20M	64	W	407.44	403.12	250	283	240	40	228	38	343	430	356	F-40430356
68-20M	68	W	432.9	428.58	250	283	240	40	228	38	366	455	382	F-40455382
72-20M	72	W	458.37	454.05	250	283	240	40	228	38	392	480	407	F-40480407
80-20M	80	W	509.3	504.98	250	283	240	40	280	38	445	530	457	F-40530457
90-20M	90	W	572.96	568.64	250	283	240	40	280	38	508	595	521	F-40595521

20M型标准皮带宽290mm

规格	齿数	形状	节径	外径	W	L	1K	X	轮毂直径	内孔	透孔外径	档边外径	档边内径	档边型号
34-20M	34	B/W	216.45	212.13	305	343	295	-	165	32	-	240	165	F-40240165
36-20M	36	B/W	229.18	224.87	305	343	295	-	178	32	-	250	178	F-40250178
38-20M	38	B/W	241.92	237.6	305	343	295	-	181	32	-	265	190	F-40265190
40-20M	40	B/W	254.56	250.33	305	343	295	-	203	32	-	275	203	F-40275203
44-20M	44	B/W	280.11	275.79	305	343	295	-	210	32	-	300	228	F-40300228
48-20M	48	B/W	305.88	301.26	305	343	295	-	228	32	-	325	254	F-40325254
52-20M	52	B/W	331.04	326.72	305	343	295	-	228	32	-	350	279	F-40350279
56-20M	56	B/W	356.51	352.19	305	343	295	-	228	32	-	375	305	F-40375305
60-20M	60	W	381.97	377.65	305	343	295	42	228	38	318	405	330	F-40405330
64-20M	64	W	407.44	403.12	305	343	295	42	228	38	343	430	356	F-40430356
68-20M	68	W	432.9	428.58	305	343	295	42	228	38	366	455	382	F-40455382
72-20M	72	W	458.37	454.05	305	343	295	42	228	38	392	480	407	F-40480407
80-20M	80	W	509.3	504.98	305	343	295	42	280	38	445	530	457	F-40530457
90-20M	90	W	572.96	568.64	305	343	295	42	280	38	508	595	521	F-40595521